



Non-destructive Testing

MARCH 2012

The electronic pdf version of this document found through <http://www.dnv.com> is the officially binding version

The content of this service document is the subject of intellectual property rights reserved by Det Norske Veritas AS (DNV). The user accepts that it is prohibited by anyone else but DNV and/or its licensees to offer and/or perform classification, certification and/or verification services, including the issuance of certificates and/or declarations of conformity, wholly or partly, on the basis of and/or pursuant to this document whether free of charge or chargeable, without DNV's prior written consent. DNV is not responsible for the consequences arising from any use of this document by others.

FOREWORD

DET NORSKE VERITAS (DNV) is an autonomous and independent foundation with the objectives of safeguarding life, property and the environment, at sea and onshore. DNV undertakes classification, certification, and other verification and consultancy services relating to quality of ships, offshore units and installations, and onshore industries worldwide, and carries out research in relation to these functions.

Classification Notes

Classification Notes are publications that give practical information on classification of ships and other objects. Examples of design solutions, calculation methods, specifications of test procedures, as well as acceptable repair methods for some components are given as interpretations of the more general rule requirements.

© Det Norske Veritas AS March 2012

Any comments may be sent by e-mail to rules@dnv.com

If any person suffers loss or damage which is proved to have been caused by any negligent act or omission of Det Norske Veritas, then Det Norske Veritas shall pay compensation to such person for his proved direct loss or damage. However, the compensation shall not exceed an amount equal to ten times the fee charged for the service in question, provided that the maximum compensation shall never exceed USD 2 million.
In this provision "Det Norske Veritas" shall mean the Foundation Det Norske Veritas as well as all its subsidiaries, directors, officers, employees, agents and any other acting on behalf of Det Norske Veritas.

CHANGES

General

This document supersedes Classification Note 7, May 2011.

Text affected by the main changes in this edition is highlighted in red colour. However, if the changes involve a whole chapter, section or sub-section, normally only the title will be in red colour.

Main Changes March 2012

- **General**

There have been several editorial amendments.

- **Appendix A, Guidelines Regarding Ultrasonic Testing of Thermo Mechanically Controlled, Processed (TMCP) Materials and Determination of the Root Area in Single Sided Welds**

— A.1.1 Introduction has been corrected with changed probe angles.

CONTENTS

1. Introduction.....	6
1.1 Preamble	6
1.2 Normative reference.....	6
1.3 Definitions and symbols	7
1.4 Safety	8
1.5 Personnel qualifications	8
1.6 Information required prior to testing	9
1.7 Extent of testing	9
1.8 Materials	9
1.9 Selection of testing method.....	10
1.10 Time of testing	10
1.11 Final report.....	10
2. Eddy Current	11
2.1 Scope.....	11
2.2 Definitions.....	11
2.3 Personnel qualifications	11
2.4 Information required (prior to testing)	11
2.5 Surface conditions	11
2.6 Equipment	12
2.7 Testing.....	13
2.8 Acceptance Criteria.....	15
2.9 Evaluation of non acceptable indication	15
2.10 Reporting.....	15
3. Magnetic Particle Testing.....	19
3.1 Scope.....	19
3.2 Definitions and symbols	19
3.3 Information required (prior to testing).....	19
3.4 Personnel qualifications	19
3.5 Magnetizing	20
3.6 Overall performance test.....	20
3.7 Preparation of surfaces.....	20
3.8 Testing.....	21
3.9 Evaluation of imperfections	25
3.10 Acceptance criteria.....	25
3.11 Demagnetization	26
3.12 Reporting.....	26
4. Penetrant testing	26
4.1 Scope.....	26
4.2 Personnel qualifications	26
4.3 Equipment/testing material	26
4.4 Compatibility of testing materials with the parts to be tested.....	27
4.5 Preparation, pre-cleaning and testing.....	27
4.6 Inspection	29
4.7 Reporting.....	29
4.8 Acceptance criteria.....	29
4.9 Post cleaning and protection	30
4.10 Retesting	30
4.11 Reporting.....	30
5. Radiographic Testing.....	31
5.1 Scope.....	31
5.2 Personnel qualifications	32
5.3 Classification of radiographic techniques.....	32
5.4 General	33
5.5 Techniques for making radiographs.....	33
5.6 Acceptance criteria.....	43
5.7 Reporting	43
6. Ultrasonic Testing	43
6.1 Scope.....	43
6.2 Definitions and symbols	44
6.3 Personnel qualifications	44
6.4 Requirements to equipment	44
6.5 Preparation of scanning surfaces	49

6.6	Testing volume	49
6.7	Welds in austenitic stainless and ferritic-austenitic (duplex) stainless steel	62
6.8	Evaluation of imperfections in weld connections	66
6.9	Acceptance Criteria, Weld Connections	66
6.10	Reporting, weld connections.....	66
6.11	Ultrasonic testing of rolled steel plates	67
6.12	Ultrasonic testing of castings	70
6.13	Ultrasonic testing of forgings.....	73
7.	Visual Inspection	75
7.1	Scope.....	75
7.2	Information required prior to testing.....	76
7.3	Requirements for personnel and equipment	76
7.4	Testing conditions	76
7.5	Testing volume.....	76
7.6	Preparation of surfaces.....	76
7.7	Evaluation of indications	76
7.8	Visual testing of repaired welds.....	77
7.9	Acceptance criteria.....	77
Appendix A.		
Guidelines Regarding Ultrasonic Testing of Thermo Mechanically Controlled, Processed (TMCP)		
Materials and Determination of the Root Area in Single Sided Welds.....		78

1. Introduction

1.1 Preamble

This Classification Note applies for non-destructive testing for the following methods:

- Eddy current testing
- Magnetic particle testing
- Penetrant testing
- Radiographic testing
- Ultrasonic testing
- Visual testing.

In general, this Classification Note has to be adhered to, as far as applicable, when non-destructive testing is required by the Society. The use of other standards or specifications may, however, be granted if an equivalent testing procedure is ensured or is more fit for the purpose.

Whenever acceptance criteria are defined in the Rules, approved drawings, IACS Recommendations or other agreed product standards, these criteria are mandatory. If no acceptance criteria are defined, acceptance criteria specified in this Classification Note may be applied.

The definitions and requirements stated below may satisfy the need of a written procedure. Where this is not the case, or where the techniques described in this Classification Note are not applicable to the object to be examined, additional written procedures shall be used and accepted by the Society before the testing is carried out.

1.2 Normative reference

This Classification Note incorporates references from other publications. These normative references are cited at the appropriate places in the text and constitute provisions of this Classification Note. Latest edition of the publications shall be used unless otherwise agreed. Other recognised publications may be used provided it can be shown that they meet or exceed the requirements of the publications referenced below.

EN 1435	Non-destructive examination of welds – Radiographic examination of welded joints
ISO 17636	Non-destructive examination of welds – Radiographic testing of fusion-welded joints
EN 444	Non-destructive testing – General principles for radiographic examination of materials by X- and gamma-rays
EN 462	Non-destructive testing – Image quality of radiographs
EN 584	Non-destructive testing – Industrial radiographic film
EN 970	Non-destructive examination of fusion welds - Visual examination
ISO 11699	Non-destructive testing – Industrial radiographic film
ISO5580	Non-destructive testing – Industrial radiographic illuminators
EN 1711	Non-destructive examination of welds – Eddy Current Examination of welds by complex plane analysis.
EN ISO 17635	Non-destructive examination of welds – General rules for fusion welds in metallic materials
EN-ISO 23277	Non-destructive examination of welds – Penetrant testing of welds – Acceptance levels.
EN 1289	Non-destructive examination of welds – Penetrant testing of welds – Acceptance levels.
EN-ISO 23278	Non-destructive examination of welds – Magnetic particle testing - Acceptance levels
EN-ISO5817	Arc-welded joints in steels – Guidance on quality levels for imperfections.
EN-ISO 6520	Classification of imperfections in metallic fusion welds with explanations.
EN-ISO 10042	Arc-welded joints in aluminium and its weldable alloys – Quality levels for imperfections.
EN 1330	Non-destructive testing – Terminology
EN-ISO 15548	Non-destructive testing – Equipment for eddy current examination.
IACS Rec. No. 47	International Association of Classification societies-Recommendation No. 47, Shipbuilding and repair Quality Standard
IACS Rec. No. 68	International Association of Classification societies – Rec. No. 68, Guidelines for non-destructive examination of hull and machinery steel forgings

IACS Rec. No. 69	International Association of Classification societies – Rec. No. 69, Guidelines for non-destructive examination of marine steel castings
EN 473	Qualification and certification of NDT personnel – General principles
ASNT	SNT-TC-1A American Society for Non-destructive testing - Recommended Practice
EN-ISO 17638	Non-destructive testing of welds, Magnetic particle testing
EN-ISO 9934-1	Non-destructive testing – Magnetic particle testing – General Principles
EN 10160	Ultrasonic testing of steel and flat product of thickness equal or greater than 6 mm (reflection method)
ISO 9712	Non-destructive testing – Qualification and certification of personnel
EN-ISO 11666	Non-destructive examination of welded joints – Acceptance levels
EN-ISO 23279	Non-destructive testing of welds – Ultrasonic examination – Characterization of indications in welds
EN-ISO 17640	Non-destructive examination of welds – Ultrasonic examination of welded joints
ASME V	ASME Boiler and Pressure Vessel Code; Non-destructive Examination
ASTM A 609	Standard Practice for Castings, Carbon, Low-Alloy, and Martensitic Stainless Steel, Ultrasonic Examination
ASTM 388	Standard Practice for Ultrasonic - Examination of Heavy Steel Forgings
EN 12668	Characterisation and verification of ultrasonic of ultrasonic equipment; Part 1 – Instruments, Part 2 – Probes, Part 3 – Combined equipment
EN-ISO 3059	Non-destructive testing – Penetrant testing– Magnetic Particle testing – Viewing conditions
ASTM E-1316	Standard Terminology for Non-destructive Examinations
EN 571	Non-destructive testing – penetrant testing
EN 956	Non-destructive testing – penetrant testing – Equipment
EN ISO 12706	Non-destructive testing – Terminology – Terms used in penetrant testing
EN14096-1	Non-destructive testing - Qualification of radiographic film digitalisation systems - Part 1: Definitions, quantitative measurements of image quality parameters, standard reference film and qualitative control
ISO 3452-1	Non-destructive testing -- Penetrant testing -- Part 1: General principles

1.3 Definitions and symbols

The following definitions apply:

- *Testing*: Testing or examination of a material or component in accordance with this Classification Note, or a standard, or a specification or a procedure in order to detect, locate, measure and evaluate flaws.
- *Defect*: One or more flaws whose aggregate size, shape, orientation, location or properties do not meet specified requirements and are rejectable.
- *Discontinuity*: A lack of continuity or cohesion; an intentional or unintentional interruption in the physical structure or configuration of a material or component
- *Flaw*: An imperfection or discontinuity that may be detectable by non-destructive testing and is not necessarily rejectable.
- *Indication*: Evidence of a discontinuity that requires interpretation to determine its significance
- *False indication*: An indication that is interpreted to be caused by a discontinuity at a location where no discontinuity exists.
- *Non relevant indication*: An indication that is caused by a condition or type of discontinuity that is not rejectable. False indications are non-relevant
- *Imperfections*: A departure of a quality characteristic from its intended condition.
- *Internal imperfections*: Imperfections that are not open to a surface or not directly accessible.
- *Quality level*: Fixed limits of imperfections corresponding to the expected quality in a specific object. The limits are determined with regard to type of imperfection, their amount and their actual dimensions.
- *Acceptance level*: Prescribed limits below which a component is accepted.
- *Planar discontinuity*: Discontinuity having two measurable dimensions
- *Non-planar discontinuity*: Discontinuity having three measurable dimensions.

The following definitions relevant to MT or PT indications apply:

- *Linear indication*: An indication in which the length is at least three times the width.
- *Nonlinear indication*: An indication of circular or elliptical shape with a length less than three times the width.
- *Aligned indication*: Three or more indications in a line, separated by 2 mm or less edge-to-edge.

- *Open indication*: An indication visible after removal of the magnetic particles or that can be detected by the use of contrast dye penetrant.
- *Non-open indication*: An indication that is not visually detectable after removal of the magnetic particles or that cannot be detected by the use of contrast dye penetrant.
- *Relevant indication*: An indication that is caused by a condition or type of discontinuity that requires evaluation. Only indications which have any dimension greater than 1.5 mm shall be considered relevant.

1.3.1 Abbreviations

ET	Eddy current testing
MT	Magnetic particle testing
PT	Penetrant testing
RT	Radiographic testing
UT	Ultrasonic testing
VT	Visual testing
HAZ	Heat affected zone
WPS	Welding Procedure Specification
TMCP	Thermo mechanically controlled processed
NDT	Non-destructive testing.

1.4 Safety

International, national and local safety and environmental protection regulation shall be observed at all times.

1.5 Personnel qualifications

Personnel performing testing shall be qualified and certified to an appropriate level in accordance with EN 473, ISO 9712 or other equivalent recognised standard or certification schemes e.g. PCN and NORDTEST. Other recognized national certification schemes may be considered.

Personnel performing non-destructive testing in accordance with this Classification Note shall be qualified and certified to an appropriate level as specified for each method.

As a minimum the following applies:

Level 1

An individual certificated to Level 1 has demonstrated competence to carry out NDT according to written instructions and under the supervision of level 2 or 3 personnel. Within the scope of the competence defined on the certificate, level 1 personnel may be authorised to:

- set up NDT equipment
- perform the test
- record and classify the results of the tests in terms of written criteria
- report the results
- Level 1 certificated personnel shall not be responsible for the choice of test method or technique to be used, nor for the assessment of the test results.

Level 2

An individual certificated to Level 2 has demonstrated competence to perform non-destructive testing according to established or recognised procedures. Within the scope of the competence defined on the certificate, level 2 personnel may be authorised to:

- select the NDT technique for the test method to be used.
- define the limitations of application of the testing method
- translate NDT standards and specifications into NDT instructions
- set up and verify equipment settings
- perform and supervise tests
- interpret and evaluate results according to applicable standards, codes or specifications
- prepare written NDT instructions
- carry out and to supervise all level 1 duties.

Level 3

An individual certificated to Level 3 has demonstrated competence to perform and direct non-destructive testing operations for which he is certificated. An individual certificated to level 3 may:

- assume full responsibility for a test facility or examination centre and staff

- establish and validate NDT instructions and procedures
- interpret standards, codes, specifications and procedures
- designate the particular test methods, procedures and NDT instructions to be used
- carry out and to supervise all level 1 and 2 duties.

Procedures and techniques shall be established and approved by personnel certified to NDT Level 3 in the applicable inspection method.

The operator shall provide evidence of satisfactory vision. The near vision acuity shall permit reading a minimum of Jaeger number 1 or Times Roman N 4.5 or equivalent letters at not less than 300 mm with one or both eyes, either corrected or uncorrected. In addition the colour vision shall be sufficient that the operator can distinguish and differentiate contrast between the colours used in the NDT method concerned as specified by the employer.

The documented test of visual acuity shall be carried out at least annually.

Site test/mock-up test is recommended carried out. For special methods such as PAUT, AUT, UT of austenitic stainless steel/duplex materials site test should be carried out.

1.6 Information required prior to testing

Before carrying out non-destructive testing, the following items, if applicable, shall be agreed between the manufacturer and the Society.

- specific testing procedure, if required
- extent of testing
- testing plan
- testing equipment
- calibration of the equipment
- calibration and reference blocks
- acceptance level
- actions necessary for unacceptable indications.

Prior to testing, the following information is usually required:

- grade of parent material
- welding parameters and conditions used to make the weld
- location and extent of welds to be tested
- weld surface geometry
- coating type and thickness.

Operators may ask for further information that will be helpful in determining the nature of discontinuities.

1.7 Extent of testing

The extent of testing shall be given in the relevant parts of the Rules or drawings or as agreed between the manufacturer and the Society.

The extent of NDT shall be increased if repeated occurrence of cracks or other significant weld defects are revealed. Corrective actions shall be taken to ensure that all similar defects will be detected.

All welds shall be 100% visually tested prior to carrying out other NDT.

1.8 Materials

This Classification Note is applicable for testing of castings, forgings, rolled materials and fusion welds in the following materials, their alloys and combinations:

- steel
- aluminium
- copper
- nickel
- titanium.

The use of this Classification Note for other metallic materials shall be approved case by case.

1.9 Selection of testing method

Selection of NDT-method is shown in Table 1-1.

NDT method	Materials	Clad		Plate	Weld				Castings	Forgings
		weld	plate		T-joint, Partial	T-joint	Butt	Fillet		
VT	All	X	X	X	X	X	X	X	X	X
MT	Ferromagnetic C and C-Mn/ Alloy/Duplex ¹⁾	-	-	X	X	X	X	X	X	X
PT	Aluminium/ Cu-Alloys/ SS/ Duplex ²⁾	X	-	X	X	X	X	X	X	X
UT ⁵⁾	Aluminium/ C and C-Mn/ Alloy/ SS/Duplex	X	X	X	³⁾	X	X	-	X	X
RT	Aluminium/ C and C-Mn/ Alloy/ SS/Duplex	-	-	-	-	-	X ⁴⁾	-	³⁾	³⁾
ET ³⁾	All	X	-	X	X	X	X	X	³⁾	³⁾

1) Methods is applicable with limitations for Duplex, shall be approved case by case
2) May be used for other materials also after special approval in each case
3) May be used after special approval in each case
4) Recommended for $t \leq 40$ mm
5) Only applicable for welds with $t \geq 10$ mm

1.10 Time of testing

If not otherwise specified in the applicable rules, the following applies:

When heat treatment is performed, the final NDT shall be carried out when all heat treatments have been completed.

For NV 420 grades and higher, final inspection and NDT shall not be carried out before 48 hours after completion.

1.11 Final report

All NDT shall be properly documented in such a way that the performed testing can be easily retraced at a later stage. The reports shall identify the unacceptable defects present in the tested area, and a conclusive statement as to whether the weld satisfies the acceptance criteria or not.

The report shall include a reference to the applicable standard, NDT procedure and acceptance criteria.

In addition, as a minimum, the following information must be given:

- object and drawing references
- place and date of examination
- material type and dimensions
- post weld heat treatment, if required
- location of examined areas, type of joint
- welding process used
- name of the company and operator carrying out the testing including certification level of the operator
- surface conditions
- temperature of the object
- number of repairs if specific area repaired twice or more
- contract requirements e.g. order no., specifications, special agreements etc.
- sketch showing location and information regarding detected defects,
- extent of testing
- test equipment used
- description of the parameters used for each method
- description and location of all recordable indications
- examination results with reference to acceptance level.
- number of repairs to be specified in the report, such as once or twice repairs in the same area.

Other information related to the specific method may be listed under each method.

The report shall be such that there is no doubt about what is tested, where it has been carried out and give a clear and exact description of reportable defect location.

2. Eddy Current

2.1 Scope

This part defines Eddy Current testing techniques (ET) for detection of surface breaking and near surface planar defects in:

- welds
- heat affected zone
- parent material.

ET can be applied on coated and uncoated objects and the testing can be carried out on all accessible surfaces on welds of almost any configuration.

Usually, it can be applied in the as-welded condition. However, a very rough surface may prevent an efficient testing.

The Eddy Current testing method includes also Alternating Current Field Measurement (ACFM). If this method is applied, written procedures shall be established according to recognised standards and are subjected for approval by the Society before the testing starts.

2.2 Definitions

In addition to definitions given in 1.3 the following applies:

2.2.1 Balance

Compensation of the signal, corresponding to the operating point, to achieve a predetermined value, for example zero point.

2.2.2 Impedance plane diagram

Graphical representation of the focus points, indicating the variation in the impedance of a test coil as a function of the test parameters.

2.2.3 Noise

Any unwanted signal which can corrupt the measurement.

2.2.4 Phase reference

Direction in the complex plane display chosen as the origin for the phase measurement.

2.2.5 Probe

Eddy current transducer. Physical device containing excitation elements and receiving elements.

2.2.6 Lift off

Geometrical effect produced by changes in the distance between the probe and the product to be tested.

2.3 Personnel qualifications

Personnel performing testing shall be qualified and certified to ET level 2 or 3 in accordance with EN 473, ISO 9712 or other equivalent recognised standard or certification schemes e.g. PCN and NORDTEST. Other recognized national certification schemes may be considered.

2.4 Information required (prior to testing)

See general information in 1.6 through 1.11.

2.5 Surface conditions

Depending on the sensitivity requirements, the eddy current method is able to detect surface cracks through non-metallic coating up to 2 mm thickness. Coating thickness in excess may be considered if the relevant sensitivity is maintained.

Excessive weld spatters, scale, rust and damaged paint can influence sensitivity by separating the probe (lift off) from the test object and shall be removed before the inspection.

It shall also be noted some types of coating, such as zinc primers, could seriously influence the results as they can deposit electrical conductive metallic material in all cracks open to the surface.

Normally, zinc rich shop primer used for corrosion protection (typical thickness max. 30 μm) will not influence the testing.

2.6 Equipment

2.6.1 Instrument

The instrument used for the testing described in this Classification Note shall at least have the following features:

2.6.1.1 Frequency

The instrument shall be able to operate at the frequency range from 1 kHz to 1 MHz.

2.6.1.2 Gain/noise

After compensation (lift off), a 1 mm deep artificial defect shall be indicated as a full screen deflection through a coating thickness corresponding to the maximum expected on the object to be tested.

Further, a 0.5 mm deep artificial defect shall be indicated through the same coating thickness by a minimum noise/signal ratio of 1 to 3.

Both requirements shall apply to the chosen probe and shall be verified on a relevant calibration block.

2.6.1.3 Evaluation mode

The evaluation mode uses both phase analysis and amplitude analysis of vector traced to the complex plane display. Evaluation may be by comparison of this display with reference data previously stored.

2.6.1.4 Signal display

As a minimum, the signal display shall be a complex plane display with the facility to freeze data on the screen until reset by the operator. The trace shall be clearly visible under all lighting conditions during the testing.

2.6.1.5 Phase control

The phase control shall be able to give complete rotation in steps of no more than 10° each.

2.6.2 Probes

2.6.2.1 Probes for measuring thickness of coating

The probe shall be capable of providing a full screen deflection lift-off signal on the instrument when moved from an uncoated spot on a calibration block to a spot covered with the maximum coating thickness expected on the object to be tested. The probe shall operate in the frequency range from 1 kHz to 1 MHz. The probes shall be clearly marked with their operating frequency range. Typical absolute probes to be used is shielded 200 KHz and 500 KHz.

2.6.2.2 Probes for weld testing

For testing of welds, probes specially designed for this purpose shall be used. The probe assembly shall be differential, orthogonal, tangential or equivalent which is characterised by having a minimal dependency on variations in conductivity, permeability and lift off in welded and heat-affected zones

The diameter of the probe shall be selected relative to the geometry of the component under test. Such probes shall be able to operate when covered by a thin layer on non-metallic wear-resistant material over the active face. If the probe is used with a cover, than the cover shall always be in place during the calibration. The probe shall operate at a selected frequency in the range from 100 kHz to 1 MHz. Typical absolute probes to be used is shielded 200 KHz and 500 KHz.

2.6.3 Accessories

2.6.3.1 Calibration block

A calibration block, of the same type of the material as the component to be tested shall be used. It shall have EDM (Electric Discharge Machined) notches of 0.5, 1.0 and 2.0 mm depth, unless otherwise agreed between contracting parties. Tolerance of notch depth shall be ± 0.1 mm. Recommended width of notch shall be ≤ 0.2 mm.

2.6.3.2 Non-metallic sheets

Non-metallic flexible strips of a known thickness to simulate the coating or actual coatings on the calibration block shall be used.

It is recommended that non-metallic flexible strips be multiples of 0.5 mm thickness.

2.6.3.3 Probe extension cables

Extension cables may only be used between the probe and the instrument if the function, sensitivity and the resolution of the whole system can be maintained.

2.6.4 Systematic equipment maintenance

The equipment shall be checked and adjusted on a periodic basis for correct functioning in accordance with recognised standards, e.g. EN 1711 or ASME V. This shall only include such measurements or adjustments, which can be made from the outside of the equipment. Electronic adjustments shall be carried out in case of device faults or partial deterioration or as a minimum on an annual basis. It shall follow a written procedure. The results of maintenance checks shall be recorded. Records shall be filed by owner.

2.7 Testing

2.7.1 General information for coating thickness

The coating thickness on the un-machined surface is never constant. However, it will influence the sensitivity of crack detection. The lift off signal obtain from the object to be tested shall be similar to the signal obtain from the calibration block, i.e. it shall be within 5° either side of the reference signal. In the event that the signal is out of this range, a calibration block more representative of the material to be tested shall be produced/ manufactured.

2.7.1.1 Calibration

- Select frequency to desired value between 1 kHz and 1 MHz, depending on probe design, for instance a broad band pencil probe 80-300 kHz set at 100 kHz.
- Place the probe on the uncovered calibration block away from slots and balance the equipment.
- Use the X- and Y-controls to adjust the position of the spot until it is on the right hand side of the screen. Move the probe on and off the calibration block. Adjust the phase angle control until the movement of the spot is horizontal.
- Place the probe on the uncovered calibration block ensuring it is not close to any of the slots. Repeat this on the same spot of the block now covered with 0.5, 1.0 and 1.5 mm non-metallic sheets.
- Note the different signal amplitudes, see Fig. 2-8.

2.7.1.2 Measuring of coating thickness

- Balance the equipment on an uncoated spot on the test object.
- Place the probe on selected spots adjacent to the weld or area to be tested. Note the signal amplitudes.
- The thickness of the coating can be estimated by interpolation between the signal amplitudes from the known thicknesses, see Fig. 2-9.
- The estimated coating thickness shall be recorded.

2.7.2 Testing of weld in Ferritic materials

2.7.2.1 Frequency

The frequency shall be chosen according to the material (conductivity, permeability), the defect (type, location, size) and the probe design. It is suggested to use a frequency around 100 kHz.

2.7.2.2 Probes

For testing of ferritic welds, probes specially designed for this purpose shall be used. They are usually of the differential coil type, which is characterised by having a minimal influence on variations in conductivity, permeability and lift-off in the welded and heat-affected zones. Such probes may further be designed for use on rather uneven surfaces as often found in welds on steel structures. (Regarding use of protective covers on probes, see 2.6.2.2)

2.7.2.3 Calibration

Calibration is performed by passing the probe over the notches in the calibration block. See Fig. 2-7 The notched surface shall first be covered by non metallic flexible strips having a thickness equal to or greater than the measured coating thickness.

The equipment sensitivity is adjusted to give increasing signals from increasing notch depths. The 1 mm deep notch shall give a signal amplitude of approximately 80% of full screen height. The sensitivity levels shall then be adjusted to compensate for object geometry.

Calibration check shall be performed periodically and at least at the beginning and the end of the shift and after every change in working conditions.

When the calibration is complete it is recommended the balance is adjusted to the centre of the display.

Calibration procedure:

- Select frequency to 100 kHz.
- Balance the equipment with the probe in air.
- Use the X- and Y- controls to adjust the spot position to the centre of the screen (X-axis) and minimum one and a half screen divisions above the bottom line (Y-axis), ensuring that no noise signal is fully displayed on the screen.
- Place the probe on the uncovered calibration block ensuring it is not close to any of the slots. Balance the equipment.
- To obtain a correct defect display, run the probe over the 2.0 mm deep slot. Care should be taken that the longitudinal axis of the probe is kept parallel to the slot and the scanning direction is at right angles to the slot. Indications from the slot will appear on the screen. The phase angle control is in the vertical upwards direction.
- The sensitivity level shall be adjusted to compensate for the coating thickness measured under 2.7.1.2 using the following procedure:
- Place the non-metallic sheets of the actual thickness corresponding to the measured coating thickness on the calibration block, or the nearest higher thickness of the non metallic sheets.

Place the probe on the covered calibration block ensuring it is not close to any of the slots and balance the equipment.

Run the probe over the 2.0 mm deep slot. Adjust the gain (dB) control until the signal amplitude from the slot is in 80% of full screen height.

2.7.2.4 Scanning

The weld surface and 25 mm of each side of the weld (including the heat-affected zones) shall be scanned with the chosen probe(s). As far as the geometry of the test objects permits, the probe shall be moved in directions perpendicular to the main direction of the expected indications. If this is unknown, or if indications in different directions are expected, at least two probe runs shall be carried out, one perpendicular to the other.

The testing can be split into two parts: the heat affected zones (25 mm each side of the weld) see Fig. 2-1, 2-2, 2-3 and the weld surface, Fig. 2-4.

It shall be noted that the reliability of the testing is highly dependent on the probe relative to the surface (weld) under test. Care shall also be taken to ensure that the probe is at the optimum angle to meet the varying surface conditions in the heat affected zone.

For probes of differential coil type, the sensitivity is affected by the orientation of the imperfection relative to the coil. Therefore, care shall be taken that this also is controlled during the testing.

Guidance note:

Especially defects with an orientation of 45° to the main direction of the probe movement can be difficult to detect.

---e-n-d---of---G-u-i-d-a-n-c-e---n-o-t-e---

2.7.2.5 Detectability of imperfections

The ability to detect imperfections depends on many factors.

Some recommendations are made below to take account of the limiting factors which affect indications detectability.

- a) Material of calibration block:
Testing of metalized welds/components require equivalent calibration blocks and established calibration procedures.
- b) Conductive coatings:
Conductive coatings reduce the sensitivity of the test. The maximum coating thickness shall also be reduced and depending on the conductivity.
- c) Non-conductive coatings:
Non-conductive coatings reduce the sensitivity of the test depending on the distance between the probe and the test object.
- d) Geometry of the object:
The shape of the object and the access of the probe to the area under test reduce the sensitivity of the test. Complex weld geometries such as cruciform and gusset plates shall be tested relative to the complex geometry and possible orientation of the indications.
- e) Orientation of coils to the indication:
Directional induced current; the induced current is directional, therefore care shall be taken to ensure that the orientation of current is perpendicular and/or parallel to the expected indication position.

Inclination; care shall be taken to ensure the optimum angle of the coils relative to the area under test is maintained.

f) Minimum size of indication:

The minimum size of indication that the eddy current method is capable to detect in ferritic steel weld in the “as welded” conditions is 1 mm deep × 5 mm long.

2.7.3 Procedure for examination of welds in other materials

As previous stated, the Eddy Current method is also applicable to welds in other materials such as aluminium, duplex, stainless steels and titanium.

The procedure for testing of such welds shall generally include the same items as in 2.7.2 but the choice of frequency, probes, calibration and scanning patterns shall be optimised to the actual materials, and may deviate considerably from what is recommended for ferritic materials.

Therefore, the testing shall be based on practical experience with suitable equipment and probes, and shall be shown in a specific procedure.

2.7.3.1 Detectability of imperfections

This part of the Classification Note is based on a sensitivity level of detecting a imperfection producing a response equal to the signal amplitude from a 2 mm deep slot with scanning pattern ensuring that 10 mm or longer defects can be found.

However, the ability to detect a imperfection depends on many factors and the present knowledge of Eddy Current method applied to welded components does not allow proposing precise criteria, they shall be fixed and agreed between contracting parties as standard rule. If an amplitude response equal to 50% of amplitude response found in scanning, the 2.0 mm notch of the calibration block used, the corresponding indication is considered as a potential defect and the relevant acceptance levels for MT or PT may apply.

2.8 Acceptance Criteria

Whenever acceptance criteria are defined in the Rules, approved drawings, IACS Recommendations or other agreed product standards, these criteria are mandatory.

2.9 Evaluation of non acceptable indication

A non acceptable indication is defined as an area displaying an abnormal signal compared to that expected from that area of the object under test.

In the event of a non acceptable indication being noted (see Fig. 2-5), a further investigation of the area is requested, e.g. by using magnetic particle testing

A longitudinal scan shall be performed and the length of the indication noted.

Where possible a single pass scan along the length of the indication shall be performed to obtain the signal amplitude. The maximum amplitude shall be noted (see Fig. 2-6).

If further clarification is still needed, or when the removal of a indication shall be verified, it is requested that the testing is supplemented with other non-destructive testing, e.g. magnetic particle testing (MT) or penetrant testing (PT).

Where a non acceptable indication is noted, but no depth information is possible alternative NDT method such as ultrasonic and/or Alternating Current Potential Drop techniques shall be used to determine the depth and orientation of the indication.

2.10 Reporting

In addition to the items listed under 1.11 Final report the following have to be included in the eddy current report:

- probes, type and frequency
- phase, e.g. 180° and/or 360°
- identification of reference blocks used
- calibration report
- reporting level, if different from acceptance level.

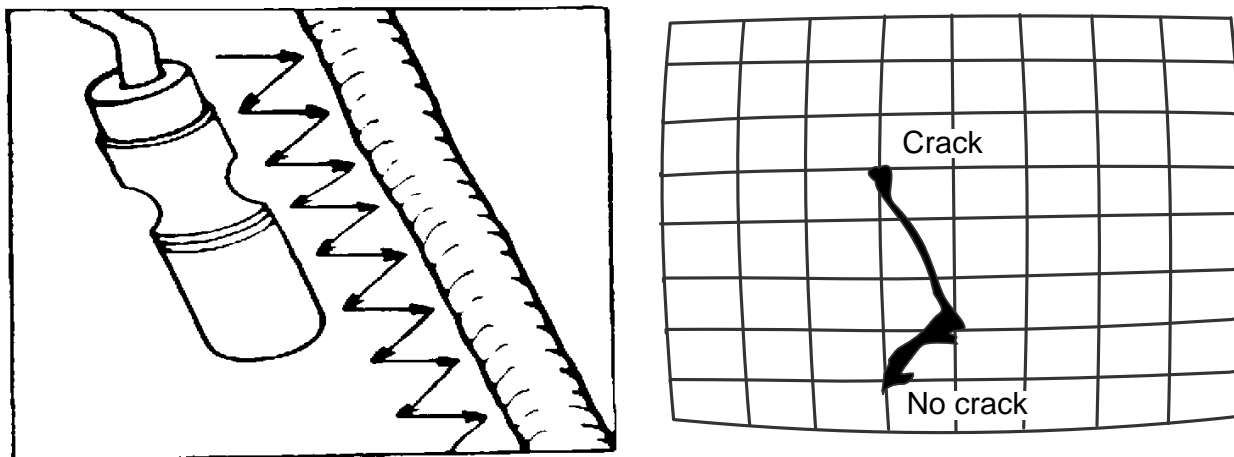

Figure 2-1
First scan of heat affected zones - Probe movement almost perpendicular to weld axis

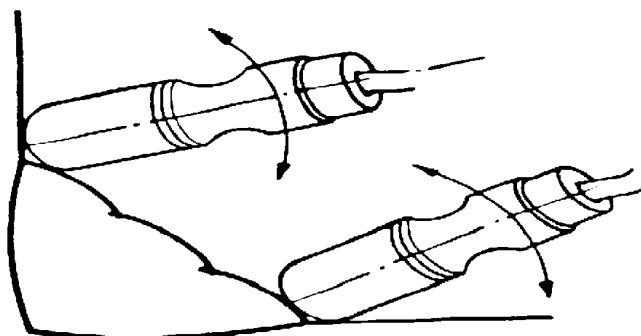

Figure 2-2
Probe angle (at scans shown in Fig. 2-1 shall be adjusted to meet varying surface conditions)

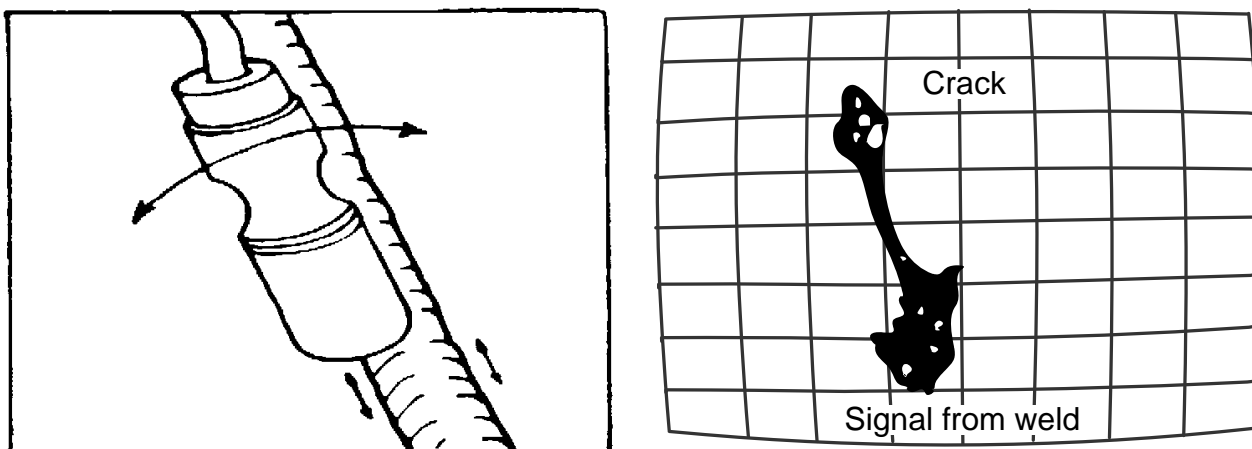

Figure 2-3
Recommended additional scans of heat affected zones - Probe movement parallel to the weld axis

Guidance note:

Both scanning patterns in Fig. 2-1 and 2-3 are mainly for longitudinal defects. Therefore, the probe orientation shall always be in position giving maximum sensitivity for the defect direction.

---e-n-d---of---G-u-i-d-a-n-c-e---n-o-t-e---

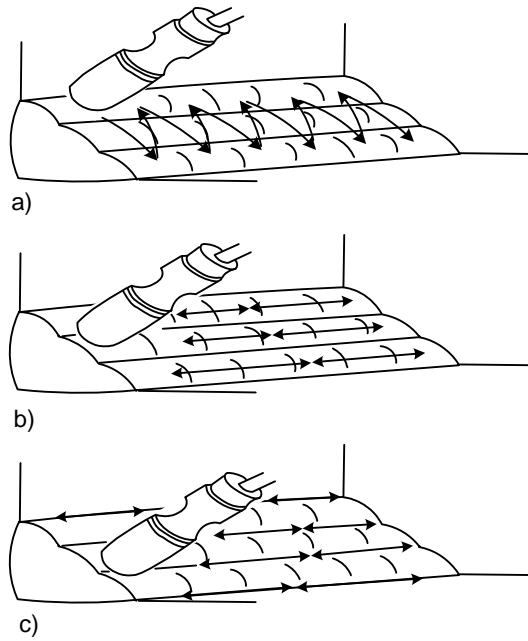

Figure 2-4
Scan of weld surface - Transverse/longitudinal scanning technique to be used relative to weld surface condition

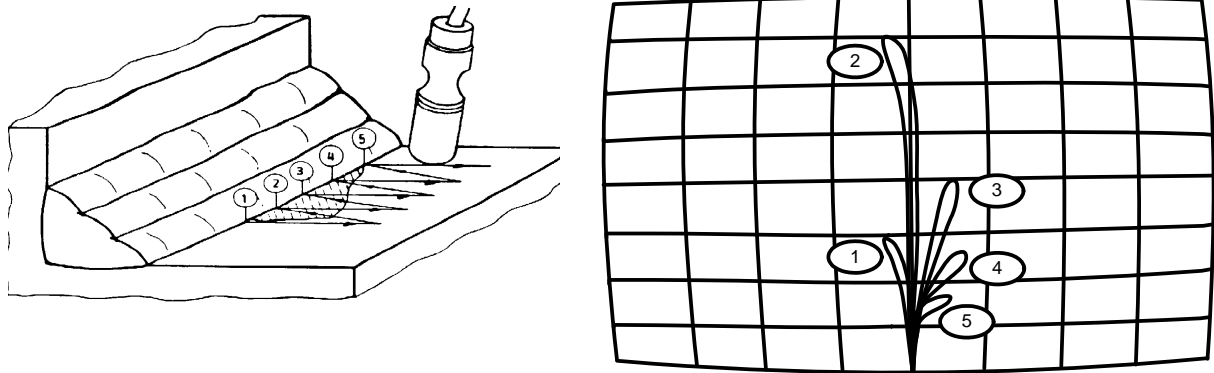

Figure 2-5
Defect evaluation using transversal scanning techniques

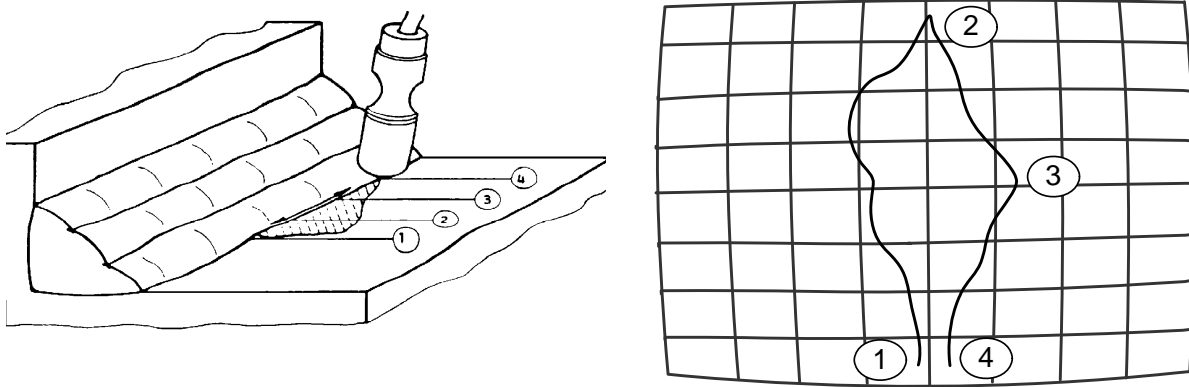

Figure 2-6
Defect evaluation using single pass longitudinal technique in heat affected zones

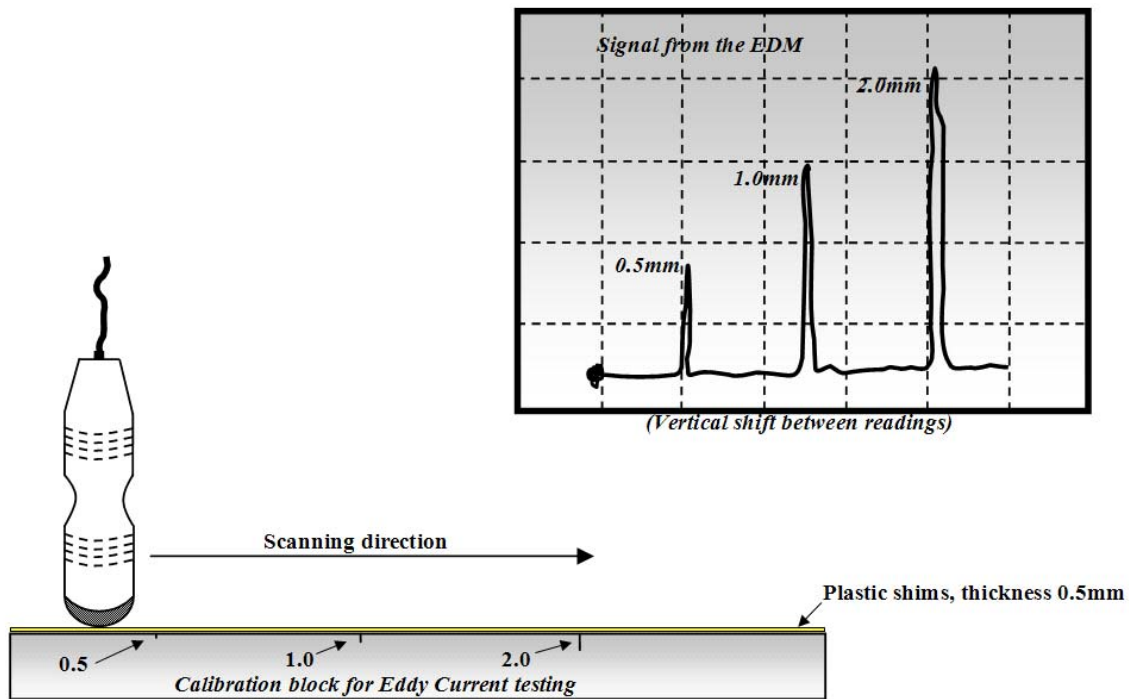

Figure 2-7
Calibration on notches

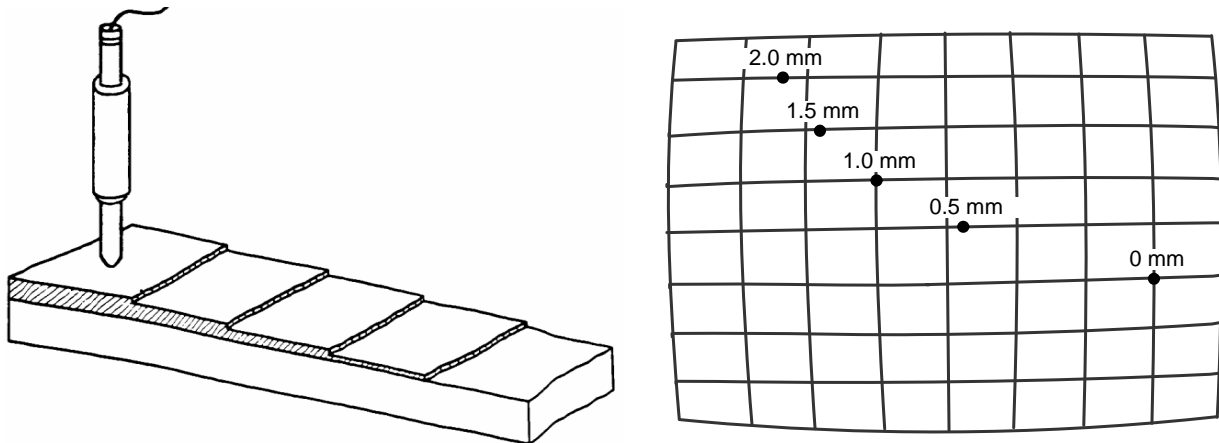

Figure 2-8
Coating thickness measurement (Calibration procedure. Vertical shift adjustment between readings)

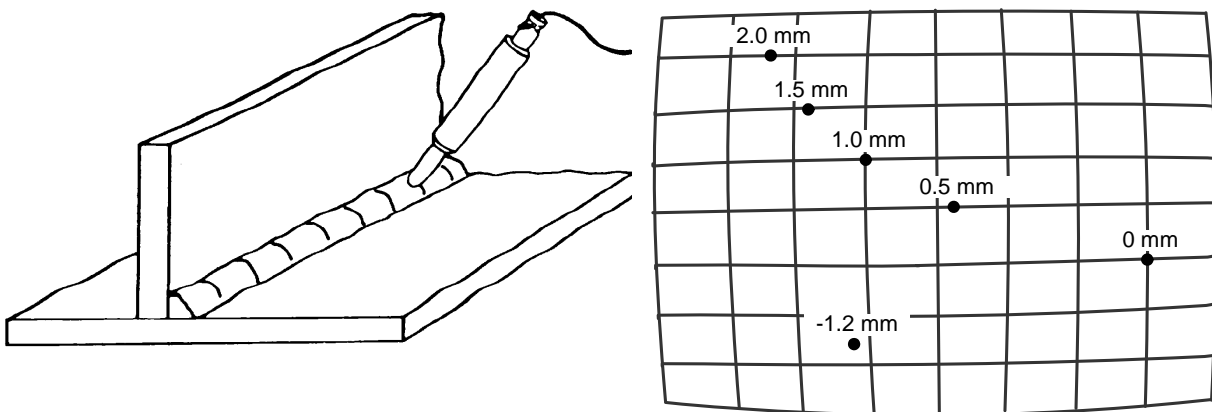

Figure 2-9
Coating Thickness Measurement. (Vertical shift adjustment between readings)

3. Magnetic Particle Testing

3.1 Scope

This part of the Classification Note specifies magnetic particle testing techniques for the detection of surface imperfections in ferromagnetic forgings, castings and welds including the heat affecting zones using the continuous wet or dry method. It can also detect imperfections just below the surface, but its sensitivity reduced rapidly with depth. If such imperfections shall be detected with high reliability, additional inspection methods shall be used. Techniques recommended are suitable for most welding processes and joint configurations.

3.2 Definitions and symbols

See 1.3.

3.3 Information required (prior to testing)

See 1.6.

3.4 Personnel qualifications

Personnel performing testing shall be qualified and certified to MT level 2 or 3 in accordance with EN 473, ISO 9712 or other equivalent recognized standard or certification schemes e.g. PCN and NORDTEST. Other recognized national certification schemes may be considered

3.5 Magnetizing

3.5.1 Equipment

Unless otherwise agreed the following types of alternate current-magnetising equipment shall be used:

- electromagnetic yoke
- current flow equipment with prods
- adjacent or threading conductors or coil techniques.

Use of alternating current

The use of alternating current gives the best sensitivity for detecting surface imperfections. Preferably, alternating current, AC electromagnetic yoke shall be used. Each AC electromagnetic yoke shall have a lifting force of at least 45 N (10 lb.) at the maximum pole space that will be used.

Use of direct current magnetization

Current flow equipment with prods and adjacent or threading conductors or coil techniques shall be specially approved by the Society in each case. Each DC electromagnetic yoke shall have a lifting force of at least 175 N (40 lb.) at the maximum pole space that will be used.

Unless otherwise agreed, use of permanent magnets shall be avoided, due to limitation of the different equipment and the difficulty to obtain sufficient magnetic field/strength for several configurations.

The magnetising equipment used shall comply with the requirements of relevant International or national standards.

Where prods are used, precautions shall be taken to minimise overheating, burning or arcing at the contact tips. Removal of arc burns shall be carried out where necessary. The affected area shall be tested by a suitable method to ensure the integrity of the surface. The prod tips should be lead, steel or aluminium to avoid copper deposit on the part being tested. Prods should not be used on machined surfaces.

When black light is used the black light must be capable of developing the required wavelengths of 330 to 390 nm with an intensity at the examination surface of not less than 1000 $\mu\text{W}/\text{cm}^2$ when measured with a suitable calibrated black light meter.

3.5.2 Verification of magnetization

The adequacy of the surface flux density shall be established by one or more of the following methods:

- by using a component containing fine natural or artificial discontinuities in the least favourable locations
- by measuring the tangential field strength as close as possible to the surface using a Hall effect probe the appropriate tangential field strength can be difficult to measure close to abrupt changes in the shape of a component, or where flux leaves the surface of a component, relevant for other techniques than yoke technique
- by calculation of the approximate tangential field strength. The calculations from the basis of current values specified in Table 3-2 and 3-3
- by verification of lifting power on material similar to test object
- other methods based on established principles.

Guidance note:

Flux indicators, placed in contact with the surfaces under examination, can provide a guide to magnitude and direction of the tangential field, but should not be used to verify that the field strength is acceptable.

---e-n-d---of---G-u-i-d-a-n-c-e---n-o-t-e---

3.6 Overall performance test

Before testing begins, a test is recommended to check the overall performance of the testing. The test shall be designed to ensure a proper functioning of the entire chain of parameters including equipment, the magnetic field strength and direction, surface characteristics, detecting media and illumination.

The most reliable test is to use representative test pieces containing real imperfections of known type, location, size and size-distribution e.g. “Pie” field indicator, ref. ASME V art.7 T-764 or “Castrol” strips type II ref. BS 6072. Where these are not available, fabricated test pieces with artificial imperfections, of flux shunting indicators of the cross or shim type may be used. The test pieces shall be demagnetized and free from indications resulting from previous tests.

3.7 Preparation of surfaces

Satisfactory results are usually obtained when the surfaces are in the as-welded, as-rolled, as-cast or as-forged conditions. However, surface preparation by grinding or machining may be necessary where surface irregularities could mask indications.

Prior to testing the surface shall be free from scale, oil, grease, weld spatter, machining marks, dirt, heavy and loose paint and any other foreign matter that can affect the sensitivity. It can be necessary to improve the surface condition e.g. by abrasive paper or local grinding to permit accurate interpretation of indications.

When testing of welds is required, the surface and all adjacent areas within 20 mm has to be prepared as described above.

There shall be a good visual contrast between the indications and the surface under test. For non-fluorescent technique, it may be necessary to apply a uniform thin, adherent layer of contrast paint. The total thickness of any paint layers shall normally not exceed 50 μm .

3.8 Testing

3.8.1 Application techniques

3.8.1.1 Field directions and examination area

The detectability of an imperfection depends on the angle of its major axis with respect to the direction to the magnetic field.

To ensure detection of imperfections in all orientations, the welds shall be magnetized in two directions approximately perpendicular to each other with a maximum deviation of 30°. This can be achieved using one or more magnetization methods.

When testing incorporates the use of yokes or prods, there will be an area of the component, in the area of each pole piece or tip that will be impossible to test due to excessive magnetic field strength, usually shown by furring of particles.

Adequate overlap of the tested areas must be ensured.

3.8.1.2 Typical magnetic particle testing techniques

Application of magnetic particle testing techniques to common weld joint configurations are shown in Tables 3-1, 3-2, and 3-3. values are given for guidance purposes only. Where possible the same directions of magnetization and field overlaps should be used for other weld geometry's to be tested. The dimension (a), the flux current path in the material, shall be greater or equal to the width of the weld and the heat affected zone +50 mm and in all cases the weld and the heat affected zone shall be included in the effective area.

Table 3-1 Typical magnetizing techniques for yokes

	Material type: Ferromagnetic material	Dimensions in mm
1		$75 \leq a \leq 250$ $b_1 \leq 0.5a$ $b_2 \leq a - 50$ (minimum overlap 50) $b_3 \leq 0.5 a$
2		$a_1 \geq 75$ $b_1 \leq 0.5a_1$ $b_2 \leq a_2 - 50$ (minimum overlap 50) $a_2 \geq 75$
3		$a_1 \geq 75$ $a_2 \geq 75$ $b_1 \leq 0.5a_1$ $b_2 \leq a_2 - 50$ (minimum overlap 50)
4		$a_1 \geq 75$ $a_2 \geq 75$ $b_1 \leq a_1 - 50$ (minimum overlap 50) $b_2 \leq 0.5 a_2$

Table 3-2 Typical magnetizing techniques for prods, using a magnetization current 5A/ mm (r.m.s.) prod spacing

	Material type: <i>Ferromagnetic material</i>	Dimensions in mm
1	 <p>Prod spacing: a (mm)</p> <p>Longitudinal cracks b_1</p> <p>Transverse cracks b_2</p> <p>All directions b_3</p>	$a \geq 75$ $b_1 \leq a - 50$ (minimum overlap 50) $b_2 \leq 0.8 a$ $b_3 \leq 0.7 a$
2	 <p>Prod spacing: a (mm)</p> <p>Transverse cracks b_1</p> <p>Longitudinal cracks b_2</p> <p>All cracks b_3</p>	$a \geq 75$ $b_1 \leq 0.8 a$ $b_2 \leq a - 50$ (minimum overlap 50) $b_3 \leq 0.7 a$
3	 <p>Prod spacing: a (mm)</p> <p>Transverse cracks b_1</p> <p>Longitudinal cracks b_2</p> <p>All cracks b_3</p>	$a \geq 75$ $b_1 \leq 0.8 a$ $b_2 \leq a - 50$ (minimum overlap 50) $b_3 \leq 0.7 a$
4	 <p>Prod spacing: a (mm)</p> <p>Longitudinal cracks b_1</p> <p>Transverse cracks b_2</p> <p>All cracks b_3</p>	$a \geq 75$ $b_1 \leq a - 50$ (minimum overlap 50) $b_2 \leq 0.8 a$ $b_3 \leq 0.7 a$

Table 3-3 Typical magnetizing techniques for flexible cables or coils

	Material type: Ferromagnetic material	Dimensions in mm
1	 <p>For longitudinal cracks</p>	$20 \leq a \leq 50$ $N \times I \geq 8 D$
2	 <p>For longitudinal cracks</p>	$20 \leq a \leq 50$ $N \times I \geq 8 D$
3	 <p>For longitudinal cracks</p>	$20 \leq a \leq 50$ $N \times I \geq 8 D$

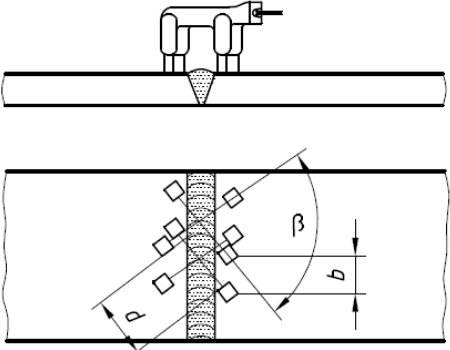
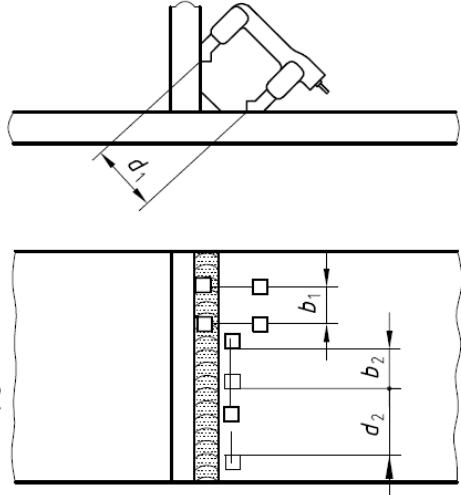
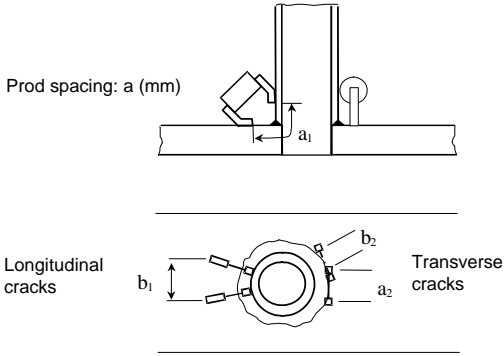
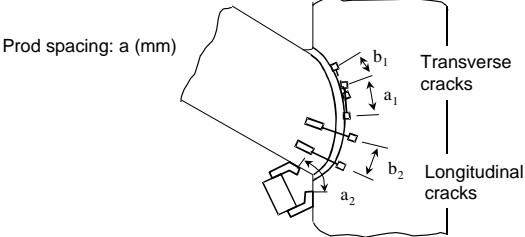
N = number of turn
I = current (r.m.s.)
a = distance between weld and coil or cable

3.8.2 Detecting media

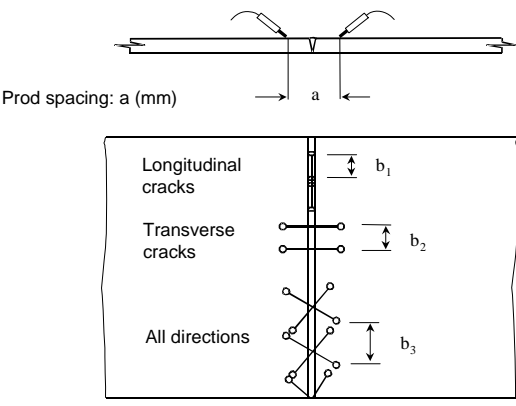
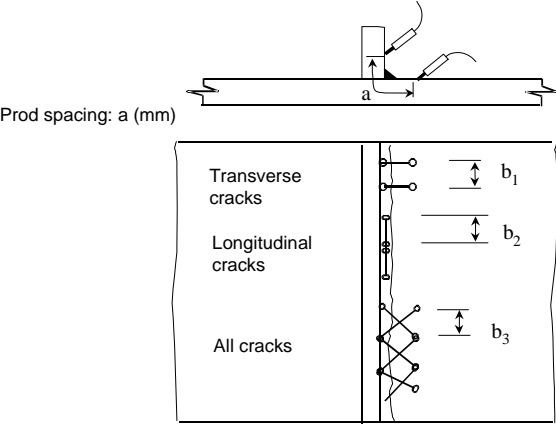
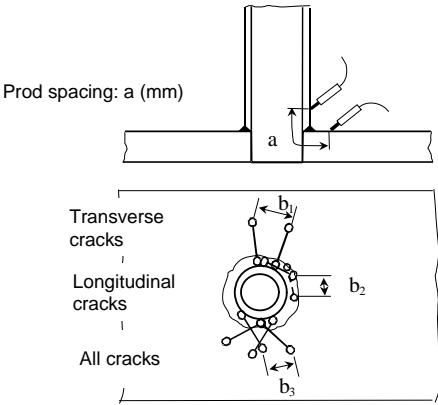
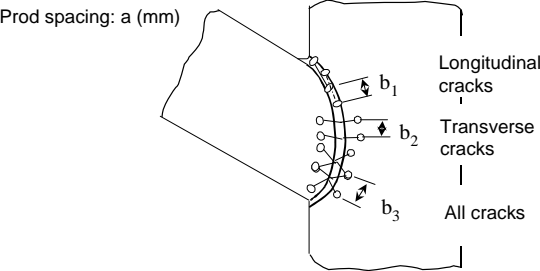
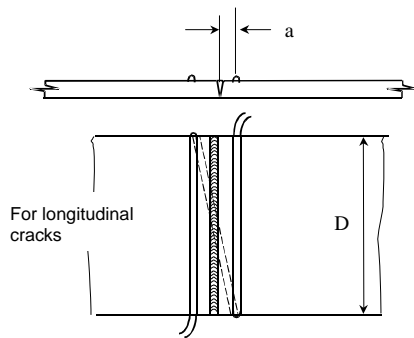
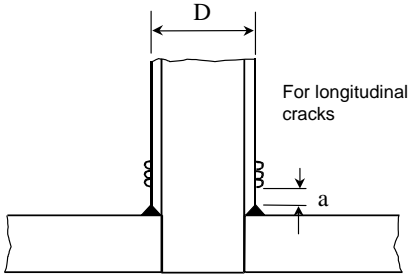
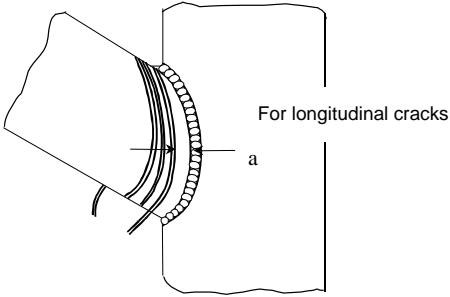
3.8.2.1 General

Detecting media may be either in dry powder or liquid form and the magnetic particles shall be either fluorescent or non-fluorescent. The detecting media shall be traceable to a batch certificate or data sheet documenting compliance with a national or international standard, e.g. ISO 9934-2 and ASME V.

3.8.2.2 Dry particles

The colour of the dry particles (dry powder) shall provide adequate contrast with the surface being examined and they may be of fluorescent or non-fluorescent type. Dry particles shall only be used if the surface temperature of the test object is in the range 57°C to 300°C.

3.8.2.3 Wet particles

The colour of the wet particles shall provide adequate contrast with the surface being examined and they are available in both fluorescent and non-fluorescent concentrates. The particles are suspended in a suitable liquid medium such as water or petroleum distillates. When using wet particle system, the temperature range of the wet particle suspension and the surface of the test object should be within $0^{\circ}\text{C} \leq T \leq 57^{\circ}\text{C}$. For temperatures below 0°C or above 57°C , procedures approved in accordance with recognised standard for this purpose shall be used. For temperatures exceeding 57°C dry particles shall be used. Checking of wet particles concentration shall be carried out based on ASME E709- Ch.20.6

3.8.2.4 Fluorescent particles

With fluorescent particles the testing is performed using an ultraviolet light, called black light. The testing shall be performed as follows:

- the testing shall be performed in darkened area where the visible light is limited to a maximum of 20 lx.
- photo chromatic spectacles shall not be used.
- sufficient time shall be allowed for the operators eyes to become dark adapted in the inspection booth, usually at least 5 min.
- UV radiation shall not be directed in the operator's eyes. All surface which can be viewed by the operators shall not fluoresce.
- the test surface shall be viewed under a UV-A radiation source. The UV-A irradiance at the surface inspected shall not be less than 10 W/m² (1000 μW/cm²).

3.8.2.5 Visible light Intensity

The test surface for colour contrast method shall be inspected under daylight or under artificial white luminance of not less than 500 lx on the surface of the tested object. The viewing conditions shall be such that glare and reflections are avoided.

3.8.3 Application of detecting media

After the object has been prepared for testing, magnetic particle detecting medium shall be applied by spraying, flooding or dusting immediately prior to and during the magnetization. Following this, time shall be allowed for indications to form before removal of the magnetic field.

When magnetic suspension are used, the magnetic field shall be maintained within the object until the majority of the suspension carrier liquid has drained away from the testing surface. This will prevent any indications being washed away.

Dependent on the material being tested, its surface condition and magnetic permeability, indications will normally remain on the surface even after removal of the magnetic field, due to residual magnetism within the part. However, the presence of residual magnetism shall not be presumed, post evaluation techniques after removal of the prime magnetic source can be permitted only when a component has been proven by an overall performance test to retain magnetic indications.

3.9 Evaluation of imperfections

Certain indications may arise, not from imperfections, but from spurious effects, such as scratches, change of section, the boundary between regions of different magnetic properties or magnetic writing. These are defined as false indications. The operator shall carry out any necessary testing and observations to identify and if possible eliminate such false indications. Light surface dressing may be of value where permitted.

3.10 Acceptance criteria

Whenever acceptance criteria are defined in the Rules, approved drawings, IACS Recommendations or other agreed product standards, these criteria are mandatory. If no acceptance criteria are defined, acceptance criteria as specified below may be applied.

The quality for welds shall normally comply with EN-ISO5817 quality level C, Intermediate. For Highly stressed areas more stringent requirements, such as Quality level B, may be applied.

Quality levels in accordance with ISO 5817	Testing techniques and levels in accordance with ISO 17638	Acceptance levels in accordance with ISO 23278
B	Level not specified	2 X
C		2 X
D		3 X

Dimensions in millimetres

Type of indication	Acceptance level ^a		
	1	2	3
Linear indication <i>l</i> = length of indication	$l \leq 1,5$	$l \leq 3$	$l \leq 6$
Non-linear indication <i>d</i> = major axis dimension	$d \leq 2$	$d \leq 3$	$d \leq 4$
^a Acceptance levels 2 and 3 may be specified with a suffix "X" which denotes that all linear indications detected shall be assessed to level 1. However the probability of detection of indications smaller than those denoted by the original acceptance level can be low.			

For hull and machinery steel forgings, IACS Recommendation No.68 is regarded as an example of an acceptable standard.

For marine steel castings IACS Rec. No. 69 is regarded as an example of an acceptable standard.

3.11 Demagnetization

After testing with alternating current, residual magnetization will normally be low for low carbon steels, and there will generally be no need for demagnetization of the object.

If required, the demagnetization shall be carried out within a method and to a level agreed. The demagnetisation shall be described in the procedure for magnetic particle testing.

3.12 Reporting

In addition to the items listed under 1.11 Final Report the following have to be included in the magnetic particle testing report:

- type of magnetization equipment
- type of current
- detection media
- viewing conditions
- demagnetization, if required.
- lifting force
- other means of magnetic field strength verification.

4. Penetrant testing

4.1 Scope

This part describes penetrant testing used to detect imperfections which are open to the surface of the tested material. It is mainly applied to metallic materials, but can also be performed on non-metallic materials, e.g. ceramics.

4.2 Personnel qualifications

Personnel performing testing shall be qualified and certified to PT level 2 or 3 in accordance with EN 473, ISO 9712 or other equivalent recognised standard or certification schemes e.g. PCN and NORDTEST. Other recognized national certification schemes may be considered

4.3 Equipment/testing material

The equipment for carrying out penetrant testing, depends on the number, size and shape of the part to be tested. A product family is understood as a combination of the penetrant testing materials.

Penetrant, excess penetrant remover and developer shall be from one manufacturer and shall be compatible with each other.

Typical testing product/testing material:

- Colour contrast penetrant, fluorescent penetrant, dual purpose penetrant.

Typical penetrant remover:

- Water, Lipofilic emulsifier, solvent and hydrophilic emulsifier.

Developers:

— Dry, water soluble, water suspendable and solvent based.

4.4 Compatibility of testing materials with the parts to be tested

The penetrant testing products shall be compatible with the material to be tested and the use for which the part is designed.

When using penetrant materials on austenitic stainless steel, titanium, nickel-based or other high-temperature alloys, the need to restrict impurities such as sulphur, halogens and alkali metals should be considered. These impurities may cause embrittlement or corrosion, particularly at elevated temperatures.

The penetrant products (penetrant, developer and remover) shall be traceable to a batch certificate or data sheet documenting compliance with a national or international standard, ref. ISO 3452-1.

4.5 Preparation, pre-cleaning and testing

4.5.1 Preparation and pre-cleaning of the surface

Contaminants, e.g. scale, rust, oil, grease or paint shall be removed, if necessary using mechanical or chemical methods or a combination of these methods. Pre-cleaning shall ensure that the test surface is free from residues and that it allows the penetrant to enter any defects/discontinuities. The cleaned area shall be large enough to prevent interference from areas adjacent to the actual test surface.

4.5.1.1 Drying

As the final stage of pre-cleaning, the object to be tested shall be thoroughly dried, so that neither water or solvent remains in the defects/discontinuities.

4.5.2 Application of penetrant

4.5.2.1 Methods of application

The penetrant can be applied to the object to be tested by spraying, brushing, flooding or immersion.

Care shall be taken to ensure that the test surface remains completely wetted throughout the entire penetration time.

4.5.2.2 Temperature

In order to minimize moisture entering defects/discontinuities, the temperature of the test surface shall generally be within the range from 10°C to 50°C. In special cases temperatures as low as 5°C may be accepted.

For temperatures below 10°C or above 50°C only penetrant product families and procedures approved in accordance with recognised standard for this purpose shall be used.

4.5.2.3 Penetration time

The appropriate penetration time depends on the properties of the penetrant, the application temperature, the material of the object to be tested and the defects/discontinuities to be detected. The penetration time shall be in accordance with the time used by the manufacturer when certifying the product family in accordance with ISO 3452-2: 2006 for certain sensitivity level or at least 15 minutes.

4.5.3 Excess penetrant removal

4.5.3.1 General

The application of the remover medium shall be done such that no penetrant is removed from the defects/discontinuities.

4.5.3.2 Water

The excess penetrant shall be removed using a suitable rinsing technique. Examples: spray rinsing or wiping with a damp cloth. Care shall be taken to minimize any detrimental effect caused by the rinsing method. The temperature of the water shall not exceed 45°C. The water pressure shall not exceed 50 psi (3.4 bar).

4.5.3.3 Solvent

Generally, the excess penetrant shall be removed first by using a clean lint-free cloth. Subsequent cleaning with a clean lint-free cloth lightly moistened with solvent shall then be carried out. Any other removal technique shall be approved by the contracting parties particularly when solvent remover is sprayed directly on to the object to be tested.

4.5.3.4 Emulsifier

Hydrophilic (water-dilutable):

To allow the post-emulsifiable penetrant to be removed from the test surface, it shall be made water rinsable by application of an emulsifier. Before the application of the emulsifier, a water wash should be performed in order to remove the bulk of the excess penetrant from the test surface and to facilitate a uniform action of the hydrophilic emulsifier which be applied subsequently.

The emulsifier shall be applied by immersion or by foam equipment. The concentration and the contact time of the emulsifier shall be evaluated by the user through pre-test according to the manufacturers' instruction. The predetermined emulsifier contact time shall not be exceeded. After emulsification, a final wash shall be carried out.

Lipophilic (oil-based):

To allow the post emulsifiable penetrant to be removed from test surface, it shall be rendered water-rinsable by application of an emulsifier. This can only be done by immersion. The emulsifier contact time shall be evaluated by the user through pre-test according to the manufacturers' instruction.

This time shall be sufficient to allow only the excess penetrant to be removed from the test surface during the subsequent water wash. The emulsifying time shall not be exceeded. Immediately after emulsification, a water wash shall be carried out.

4.5.3.5 Water and solvent

First the excess water washable penetrant shall be removed with water. Subsequent cleaning with a clean lint-free cloth, lightly moistened, with solvent shall be then carried out.

4.5.3.6 Excess penetrant removal check

During excess penetrant removal the test surface shall be visually checked for penetrant residues. For fluorescent penetrants, this shall be carried out under a UV-A source.

4.5.4 Drying

In order to facilitate rapid drying of excess water, any droplets and puddles of water shall be removed from the object.

Except when using water-based developer the test surface shall be dried as quickly as possible after excess penetrant removal, using one of the following methods:

- wiping with clean, dry, lint-free cloth
- forced air circulation
- evaporation at elevated temperature.

If compressed air is used, particular care shall be taken to ensure that it is water and oil-free and applied pressure on surface of the object is kept as low as possible.

The method of drying the object to be tested shall be carried out in a way ensuring that the penetrant entrapped in the defects/discontinuities does not dry.

The surface temperature shall not exceed 45°C during drying unless otherwise approved.

4.5.5 Application of developer

The developer shall be maintained in a uniform condition during use and shall be evenly applied to the test surface. The application of the developer shall be carried out as soon as possible after the removal of excess penetrant.

4.5.5.1 Dry powder

Dry powder may only be used with fluorescent penetrants. The developer shall be uniformly applied to the test surface by one of the following techniques: dust storm, electrostatic spraying, flock gun, fluidized bed or storm cabinet. The test surface shall be thinly covered; local agglomerations are not permitted.

4.5.5.2 Water-suspendable developer

A thin uniform application of the developer shall be carried out by immersion in agitated suspension or by spraying with suitable equipment in accordance with the approved procedure. Immersion time and temperature of the developer shall be evaluated by the user through pre-test according to the manufacturers' instruction.

The immersion time shall be as short as possible to ensure optimum results.

The object shall be dried by evaporation and/or by the use of a forced air circulation oven.

4.5.5.3 Solvent-based developer

The developer shall be applied by spraying uniformly. The spray shall be such that the developer arrives

slightly wet on the surface, giving a thin, uniform layer. Usually this requires a spraying distance of minimum 300 mm.

4.5.5.4 *Water soluble developer*

A thin uniform application of the developer shall be carried out by immersion or by spraying with suitable equipment in accordance with approved procedure. Immersion time and temperature of the developer shall be evaluated by the user through pre-test according to the manufacturers' instruction. The immersion time should be as short as possible to ensure an optimum result.

The object shall be dried by evaporation and/or by the use of a forced air circulation oven.

4.5.5.5 *Development time*

The development time shall as a minimum be the same as the penetration time, however, longer times may be agreed. The development time shall be stated in the test procedure to ensure repeatable test results with respect to defect sizing. The development time begins:

- immediately after application when dry developer is applied
- immediately after drying when wet developer is applied.

To verify the penetrant procedure it is recommended to use a reference object with known defects such as test panel described in ISO 3452-3 or equivalent. The reference object and penetrant products shall before testing achieve the same temperature as relevant for the actual testing to be performed. The minimum defect size to be detected shall respond to the maximum acceptable defect size.

4.6 Inspection

4.6.1 General

Generally, it is advisable to carry out the first examination just after the application of the developer or soon as the developer is dry. This facilitates a better interpretation of indications.

The final inspection shall be carried out when the development time has elapsed.

Equipment for visual examination, such as magnification instruments or contrast spectacles, can be used.

4.6.2 Viewing conditions

4.6.2.1 *Fluorescent penetrant*

Photo chromatic spectacles shall not be used.

Sufficient time shall be allowed for the operators eyes to become dark adapted in the inspection booth, usually at least 5 min.

UV radiation shall not be directed in the operator's eyes.

The test surface shall be viewed under a UV-A radiation source. The UV-A irradiance at the surface inspected shall not be less than 10 W/m² (1000 μW/cm²).

The statement above shall apply to inspections in darkened rooms where the visible light is limited to a maximum of 20 lx.

4.6.2.2 *Colour contrast penetrant*

The test surface shall be inspected under daylight or under artificial white an luminance of not less than 500 lx on the surface of the tested object. The viewing conditions shall be such that glare and reflections are avoided.

4.7 Reporting

Recording may be done by any of the following methods:

- written description
- sketch
- photograph
- photocopy
- video.

4.8 Acceptance criteria

Whenever acceptance criteria are defined in the Rules, approved drawings, IACS Recommendations or other agreed product standards, these criteria are mandatory. If no acceptance criteria are defined, acceptance criteria as specified below may be applied.

The indication produced by penetrant testing do not usually display the same size and shape characteristics as the imperfections causing that indication, it is the size of the indication, (*bleed out*) which shall be assessed

against the values shown below or referred to.

4.8.1 Welds

The quality shall normally comply with level 2. For highly stressed areas more stringent requirements, such as Level 1, may be applied.

Type of indication	Acceptance level ¹⁾		
	1	2	3
Linear indication <i>l</i> = length of indication	$l \leq 2 \text{ mm}$	$l \leq 4 \text{ mm}$	$l \leq 8 \text{ mm}$
Non-linear indication <i>d</i> = major axis dimension	$d \leq 4 \text{ mm}$	$d \leq 6 \text{ mm}$	$d \leq 8 \text{ mm}$
1) Acceptance levels 2 and 3 may be specified with suffix "x" which denotes that all linear indications detected shall be evaluated to level 1. However, the probability of detection of indications smaller than those denoted by the original acceptance level can be low. Linear defect such like crack, lack of fusion and lack of penetration is NOT acceptable regardless of length.			

4.8.2 Forgings

For hull and machinery forgings, IACS Recommendation No.68 is regarded as an example of an acceptable standard.

4.8.3 Castings

For marine steel castings IACS Rec. No. 69 is regarded as an example of an acceptable standard.

4.9 Post cleaning and protection

4.9.1 Post cleaning

After final inspection, post cleaning of the object is necessary only in those cases where the penetrant testing products could interfere with subsequent processing or service requirements.

4.9.2 Protection

If required a suitable corrosion protection shall be applied.

4.10 Retesting

If retesting is necessary, e.g. because no unambiguous evaluation of indication is possible, the entire test procedure, starting with the pre cleaning, shall be repeated.

The use of a different type of penetrant or a penetrant of the same type from a different supplier is not allowed unless a thorough cleaning has been carried out to remove penetrant residues remaining in the defects/discontinuities.

4.11 Reporting

In addition to the items listed under 1.11 Final Report the following have to be included in the penetrant testing report:

- penetrant system used, e.g. coloured or fluorescent
- penetrant product
- application methods
- penetration and development time
- viewing conditions
- test temperature.

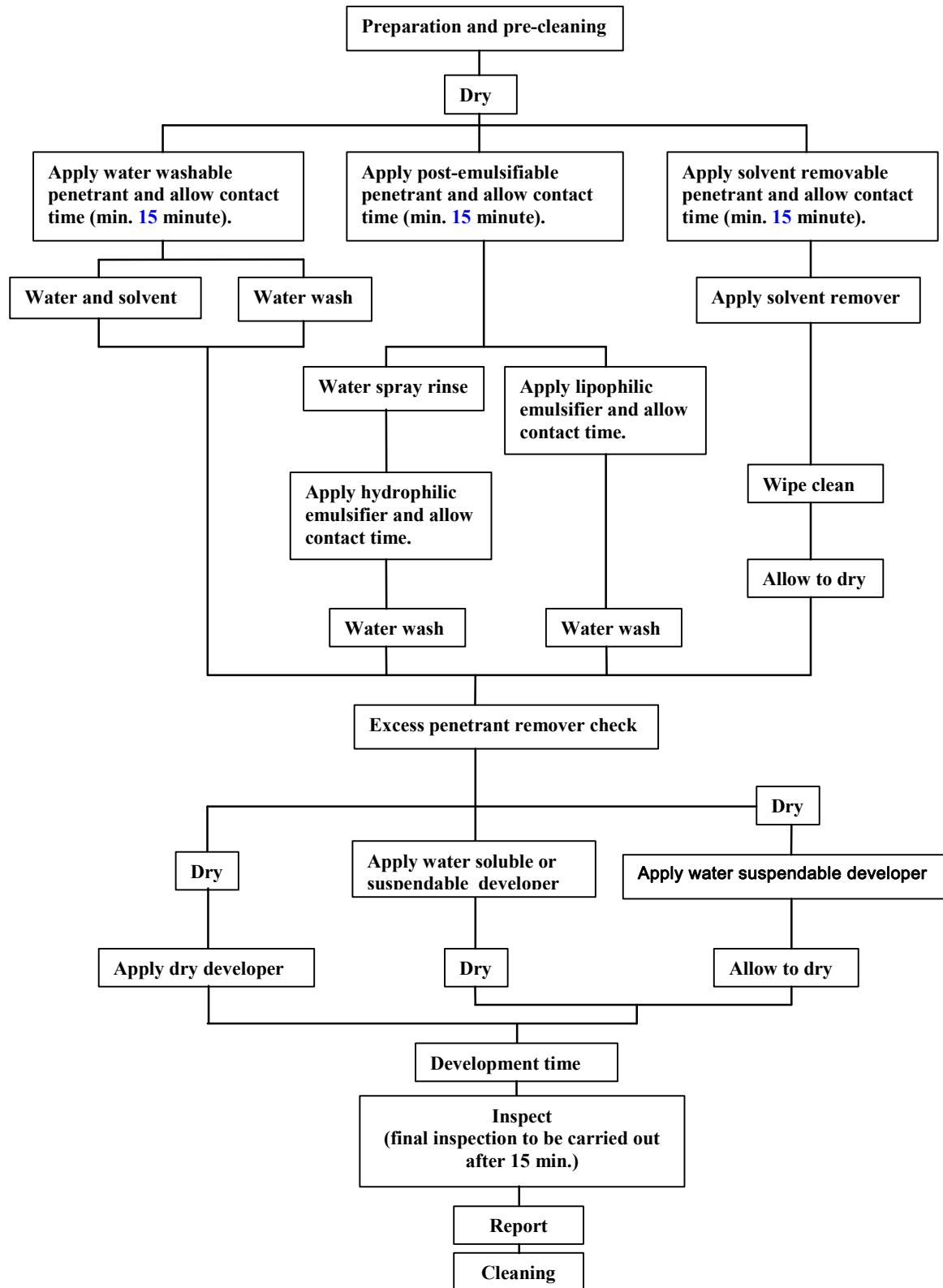

Figure 4-1
Main stages of penetrant testing

5. Radiographic Testing

5.1 Scope

This part describes fundamental techniques for radiography with the object of enable satisfactory and repeatable results. The techniques are based on generally recognized practice and fundamental theory of the

subject. This part of the Classification Note applies to the radiographic testing of fusion welded joints in metallic materials. However, it may be applied for flaw detection of non-welded metallic materials also. For radiographic testing of forgings and castings specific procedures in accordance with recognised standards has to be established and approved by the Society.

Typical applications which require specific RT procedures are:

- digital radiography e.g. EN 14096
- real time radiography e.g. EN 14784
- radiosopic testing e.g. EN 13068.

5.1.1 Definitions and symbols

See item 1.3 under the Introduction chapter of this Classification Note, in addition the following applies:

Nominal thickness, t: The nominal thickness of the parent material only. Manufacturing tolerances do not have to be taken into account.

Penetrated thickness, w: The thickness of the material in the direction of the radiation beam calculated on the basis of the nominal thickness.

Object - to - film distance, b: The distance between the radiation side of the test object and the film surface measured along the central axis of the radiation beam.

Source size, d: The size of the radiation source.

Source - to - film distance, SFD: The distance between the source of radiation and the film measured in the direction of the beam.

Source - to - object distance, f: The distance between the source of the radiation and the source side of the test object measured along the central axis of the radiation beam.

Effective film length, EFL: The area of the film that shall be interpreted

Minimum source to object distance min., f_{\min} : The minimum allowable distance between the focal spot and the source side of the object

Diameter, D_e : The nominal external diameter of the pipe/tube.

5.2 Personnel qualifications

Personnel performing testing shall be qualified and certified to RT level 2 or 3 in accordance with EN 473, ISO 9712 or other equivalent recognised standard or certification schemes e.g. PCN and NORDTEST. Other recognized national certification schemes may be considered.

Requirements for radiation protection qualification should be in accordance with national or international standards.

However, operators only producing radiographs and not performing final film interpretation, may be qualified and certified to RT level 1.

5.3 Classification of radiographic techniques

The radiographic techniques are divided into two classes:

- Class A: Basic techniques
- Class B: Improved techniques.

The choice of techniques shall be in accordance with Table 5-1. Normally Class B techniques shall be applied when using Ir 192 sources, if not otherwise agreed.

If, for technical reasons, it is not possible to meet one of the conditions specified for Class B, such as type of radiation source or the source to object distance, f , the condition specified for Class A may be used. However, the loss of sensitivity shall be compensated by use of a higher contrast film system.

Table 5-1 Radiographic testing	
<i>Quality levels in accordance with ISO5817 or ISO 10042</i>	<i>Radiographic techniques</i>
B	Class B
C	Class B ¹⁾
D	Class A
1) The maximum area for a single exposure may correspond to the requirements of class A	

5.4 General

5.4.1 Protection against ionizing

When using ionizing radiation, local, national or international safety precautions shall be strictly applied.

5.4.2 Surface preparation

The inside and outside surfaces of the welds to be tested by x-ray/gamma-ray are to be sufficiently free from irregularities that may mask or interfere with the interpretation.

5.4.3 Film identification

Each radiograph is to be properly marked to clearly indicate the hull number or other equivalent traceable identification and to identify the exact location of the area of interest. The images of these symbols shall appear in the radiograph outside the region of interest where possible. Permanent markings shall be made on the object to be tested, in order to accurately locate the position of each radiograph. Where the nature of the material and/or service conditions do not permit permanent marking, the location may be recorded by means of accurate sketches.

If the weld would not appear clearly on the radiograph due to flush grinding, markers, usually in the form of lead arrows or other symbols, shall be placed on each side of the weld.

The images of these letters should appear in the radiograph to ensure unequivocal identification of the section.

5.4.4 Overlap of films

When exposing radiographs of an area with two or more separate films, the films shall show overlap sufficiently to ensure that the complete region of interest is tested. This shall be verified by high density marker placed on the surface of the object which will appear on each film.

5.5 Techniques for making radiographs

5.5.1 Types and position of Image quality indicator (IQI)

The quality of the image shall be verified by use of an IQI.

IQI shall be selected from either the same alloy material group or grade or from an alloy material group with less radiation absorption than the material being tested.

The IQI used shall preferably be placed on the source side of the test object and in close contact with the surface of the object. The IQI shall be located in a section of a uniform thickness characterized by a uniform optical density on the film. If not otherwise approved, wire penetrometer should be used.

The wires shall be perpendicular to the weld and its location shall ensure that at least 10 mm of the wire length shows in a section of uniform optical density, which is normally in the parent metal adjacent to the weld. The IQI is to be placed on the side of weld facing the source of radiation (source side) in the worst geometrical position which is required at either end of the applicable length of weld under inspection.

If an IQI cannot be physically placed on the side of the weld facing the source of radiation, the IQI may be placed in contact with the back surface of the weld. This is to be indicated by the placement of a lead letter "F" near the IQI and this shall be recorded in the test report.

For pipe diameter, $D_e \geq 200$ mm and with the source centrally located, at least three IQIs should be placed equally spaced at the circumference. The film(s) showing IQI image(s) are then considered representative of the whole circumference.

5.5.2 Evaluation of image quality

The image of the IQI on the radiograph shall be tested and the number of the smallest wire which can be observed shall be determined. The image of the wire is acceptable if a continuous length of at least 10 mm is clearly visible in a section of uniform optical density.

The Tables 5-2 to 5-7 show the minimum quality values for ferrous materials. They may be applied for non-ferrous materials also if not otherwise agreed.

Table 5-2 Single-wall technique, wire IQI on source side ¹⁾		
<i>Image Quality Class A</i>		
<i>Nominal thickness, t, (mm)</i>	<i>Nominal wire diameter (mm)</i>	<i>IQI value ²⁾</i>
$t \leq 1.2$	0.063	W18
$1.2 < t \leq 2$	0.080	W17
$2 < t \leq 3.5$	0.100	W16
$3.5 < t \leq 5$	0.125	W15
$5 < t \leq 7$	0.16	W14
$7 < t \leq 10$	0.20	W13
$10 < t \leq 15$	0.25	W12
$15 < t \leq 25$	0.32	W11
$25 < t \leq 32$	0.40	W10
$32 < t \leq 40$	0.50	W9
$40 < t \leq 55$	0.63	W8
$55 < t \leq 85$	0.80	W7
$85 < t \leq 150$	1.0	W6
$150 < t \leq 250$	1.25	W5
$t > 250$	1.60	W4
1) If it is not possible to place the IQI on the source side, the IQI shall be placed on the film side and the image quality determined from comparison exposure with one IQI placed on the source side and one on the film side under the same conditions 2) When using Ir 192 sources, IQI values lower than listed values can be accepted as follows: — 10 mm to 25 mm: up to 2 values, — above 25 mm to 32 mm: up to 1 value		

Table 5-3 Single-wall technique, wire IQI on source side ¹⁾		
<i>Image Quality Class B</i>		
<i>Nominal thickness, t, (mm)</i>	<i>Nominal wire diameter (mm)</i>	<i>IQI value ²⁾</i>
$T \leq 1.5$	0.050	W19
$1.5 < t \leq 2.5$	0.063	W18
$2.5 < t \leq 4$	0.080	W17
$4 < t \leq 6$	0.100	W16
$6 < t \leq 8$	0.125	W15
$8 < t \leq 12$	0.16	W14
$12 < t \leq 20$	0.20	W13
$20 < t \leq 30$	0.25	W12
$30 < t \leq 35$	0.32	W11
$35 < t \leq 45$	0.40	W10
$45 < t \leq 65$	0.50	W9
$65 < t \leq 120$	0.63	W8
$120 < t \leq 200$	0.80	W7
$200 < t \leq 350$	1.0	W6
$t > 350$	1.25	W5
1) If it is not possible to place the IQI on the source side, the IQI shall be placed on the film side and the image quality determined from comparison exposure with one IQI placed on the source side and one on the film side under the same conditions 2) When using Ir 192 sources, IQI values lower than listed values can be accepted as follows: — 12 mm to 45 mm: up to 1 value		

Table 5-4 Double-wall technique, double image, IQI on source side

<i>Image Quality Class A</i>		
<i>Penetrated thickness, w, (mm)</i>	<i>Nominal wire diameter (mm)</i>	<i>IQI value</i>
$w \leq 1.2$	0.063	W18
$1.2 < w \leq 2$	0.080	W17
$2 < w \leq 3.5$	0.100	W16
$3.5 < w \leq 5$	0.125	W15
$5 < w \leq 7$	0.16	W14
$7 < w \leq 12$	0.20	W13
$12 < w \leq 18$	0.25	W12
$18 < w \leq 30$	0.32	W11
$30 < w \leq 40$	0.40	W10
$40 < w \leq 50$	0.50	W9
$50 < w \leq 60$	0.63	W8
$60 < w \leq 85$	0.80	W7
$85 < w \leq 120$	1.0	W6
$120 < w \leq 220$	1.25	W5
$220 < w \leq 380$	1.60	W4
$w > 380$	2.00	W3

Table 5-5 Double-wall technique, double image, IQI on source side

<i>Image Quality Class B</i>		
<i>Penetrated thickness, w, (mm)</i>	<i>Nominal wire diameter (mm)</i>	<i>IQI value</i>
$w \leq 1.5$	0.050	W19
$1.5 < w \leq 2.5$	0.063	W18
$2.5 < w \leq 4$	0.080	W17
$4 < w \leq 6$	0.100	W16
$6 < w \leq 8$	0.125	W15
$8 < w \leq 15$	0.16	W14
$15 < w \leq 25$	0.20	W13
$25 < w \leq 38$	0.25	W12
$38 < w \leq 45$	0.32	W11
$45 < w \leq 55$	0.40	W10
$55 < w \leq 70$	0.50	W9
$70 < w \leq 100$	0.63	W8
$100 < w \leq 170$	0.80	W7
$170 < w \leq 250$	1.0	W6
$w > 250$	1.25	W5

Table 5-6 Double-wall technique, single or double image, IQI on film side

<i>Image Quality Class A</i>		
<i>Penetrated thickness, w, (mm)</i>	<i>Nominal wire diameter (mm)</i>	<i>IQI value</i>
$w \leq 1.2$	0.063	W18
$1.2 < w \leq 2$	0.080	W17
$2 < w \leq 3.5$	0.100	W16
$3.5 < w \leq 5$	0.125	W15
$5 < w \leq 10$	0.16	W14
$10 < w \leq 15$	0.20	W13
$15 < w \leq 22$	0.25	W12

$22 < w \leq 38$	0.32	W11
$38 < w \leq 48$	0.40	W10
$48 < w \leq 60$	0.50	W9
$60 < w \leq 85$	0.63	W8
$85 < w \leq 125$	0.80	W7
$125 < w \leq 225$	1.0	W6
$225 < w \leq 375$	1.25	W5
$w > 375$	1.60	W4

<i>Image Quality Class B</i>		
<i>Penetrated thickness, w, (mm)</i>	<i>Nominal wire diameter (mm)</i>	<i>IQI value</i>
$w \leq 1.5$	0.050	W19
$1.5 < w \leq 2.5$	0.063	W18
$2.5 < w \leq 4$	0.080	W17
$4 < w \leq 6$	0.100	W16
$6 < w \leq 12$	0.125	W15
$12 < w \leq 18$	0.16	W14
$18 < w \leq 30$	0.20	W13
$30 < w \leq 45$	0.25	W12
$45 < w \leq 55$	0.32	W11
$55 < w \leq 70$	0.40	W10
$70 < w \leq 100$	0.50	W9
$100 < w \leq 180$	0.63	W8
$180 < w \leq 300$	0.80	W7
$w > 300$	1.0	W6

The image quality obtained shall be recorded on the radiographic testing report.

The type of IQI used shall also be clearly stated.

5.5.3 Test Arrangement

The radiographic techniques in accordance with Fig. 5-1 through 5-7 are recommended.

The elliptical technique in accordance with Fig. 5-3 should not be used for external diameters $D_e > 100$ mm, wall thickness $t > 8$ mm and weld widths $> D_e / 4$. Two 90° displaced image are sufficient if $t / D_e < 0.12$. The distance between the two weld images shall be about one weld width.

When it is difficult to carry out an elliptic test at $D_e \leq 100$ mm, the perpendicular technique in accordance with Fig. 5-4 should be used. In this case three exposures 120° or 60° apart are required.

For test arrangements in accordance with Fig. 5-3, 5-4 and 5-5, the inclination of the beam shall be kept as small as possible and be such as to prevent superimposition of the two images.

Other radiographic techniques may be used, when the geometry of the piece or differences in material thickness do not permit use of one of the techniques listed in Fig. 5-1 to 5-9. Multi-film techniques shall not be used to reduce exposure times on uniform sections. The use of multi-film techniques shall be pre-qualified.

Guidance note:

The minimum number of radiographs necessary to obtain an acceptable radiographic coverage of the total circumference of a butt weld in pipe shall be in accordance with a recognised standard.

---e-n-d---of---G-u-i-d-a-n-c-e---n-o-t-e---

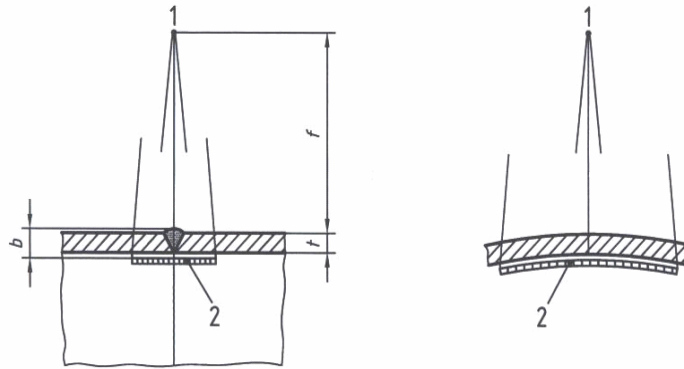

1 Radiation source

2 Film

b The distance between the radiation side of the test object and the film surface measured along the central axis of the radiation beam

f The distance between the source of the radiation and the source side of the test object measured along the central axis of the radiation beam

t The nominal thickness of the parent material.

Figure 5-1

Test arrangement - for plane walls and single-wall penetration and single wall penetration of curved objects

The ratio of the penetrated thickness at the outer edge of an evaluated area of uniform thickness to that at the beam centre shall not be more than 1.2 for class A and 1.1 for class B. This means that the effective film length (EFL) shall be in the area between the perpendicular central beam and sideways in both directions inside the nominal thickness plus 20% or 10% respectively.

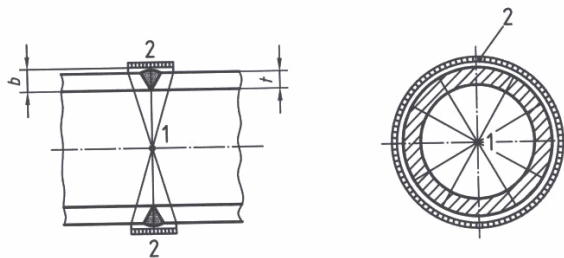

Figure 5-2

Test arrangement - for single wall penetration of curved objects

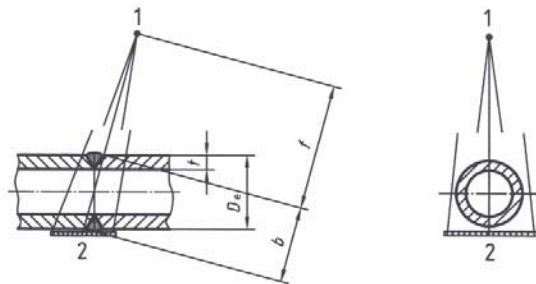

Figure 5-3

Test arrangement - for elliptical technique of curved objects for evaluation of both walls (source and film outside the test object)

This technique may be used for pipe diameter ≥ 100 mm, wall thickness (t) 8 mm and weld width less than $D/$

4. It is sufficient with two 90° displaced images if $t/D < 0.12$. The distance between the two weld images shall be about one weld width.

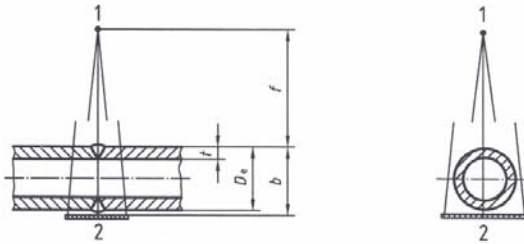

Figure 5-4

Test arrangement - for double-wall/ double image technique of curved objects for evaluation of both walls (source and film outside the test object)

The perpendicular technique may be used when the pipe diameter (\varnothing) is ≤ 100 mm and/or the wall thickness (t) > 8 mm. The perpendicular technique shall in general be applied when the t/D ratio is > 0.12 . When the wall thickness is above 12 mm four (4) exposures shall be made.

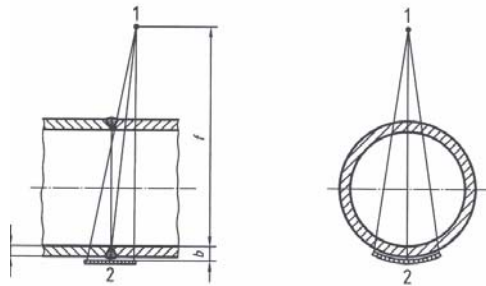

Figure 5-5

Test arrangement - for double-wall technique single image of curved objects for evaluation of the wall next to the film with the IQI placed close to the film

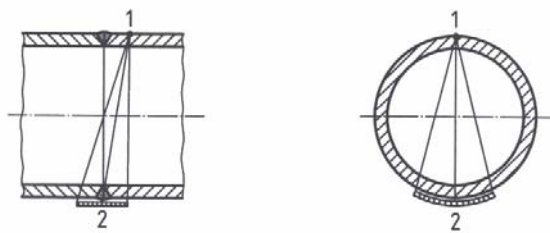

Figure 5-6

Test arrangement - for double-wall technique single image (contact) technique for pipe diameter > 100 mm

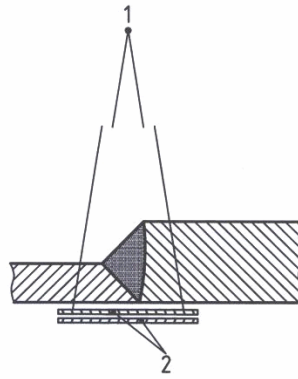

Figure 5-7
Multi-film technique - for different material thicknesses

5.5.4 Choice of tube voltage and radiation source

5.5.4.1 X-ray devices up to 500 kV

To maintain good flaw sensitivity, the X-ray tube voltage should be as low as possible. The maximum values of tube voltage versus thickness are given in Fig. 5-8

For some applications where there is a thickness change across the area of object being tested, a modified technique with a slightly higher voltage may be used, but it should be noted that an excessively high tube voltage will lead to a loss of detection sensitivity. For steel the increment shall not be more than 50 kV, for titanium not more than 40 kV and for aluminium not more than 30 kV.

- 1 Copper/nickel and alloys.
- 2 Steel.
- 3 Titanium and alloys.
- 4 Aluminium and alloys.

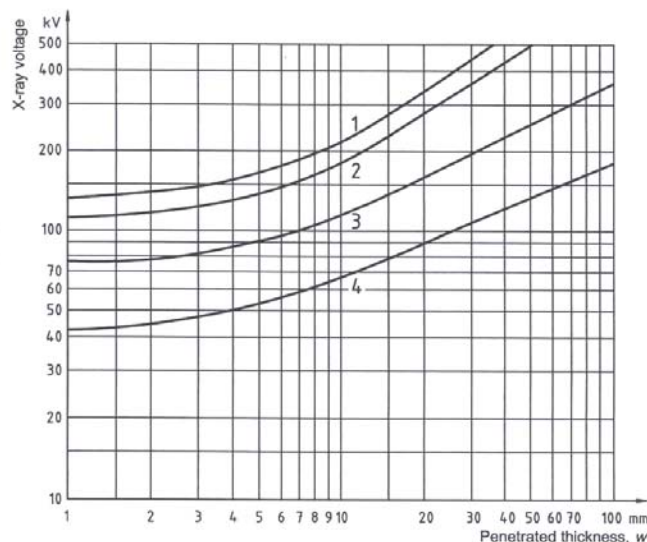

Figure 5-8
Maximum X-ray voltage - for X-ray devices up to 500 kV as a function of penetrated thickness and material

5.5.4.2 Other radiation sources

The permitted penetrated thickness ranges for gamma ray sources are given in Table 5-8.

For certain applications wider wall thickness range may be permitted, if sufficient image quality can be

achieved. X-ray equipment with energy 1 MeV and above may be used if special approved by the Society.

On thin steel specimens, gamma rays from Se 75, Ir 192 and Co 60 will not produce radiographs having as good defect detection sensitivity as X-rays used with appropriate techniques and parameters.

In cases where radiographs are produced using gamma rays, the travel time to position the source shall not exceed 10% of the total exposure time.

<i>Radiation source</i>	<i>Penetrated thickness, w mm</i>	
	<i>Test class A</i>	<i>Test class B</i>
Se75 ¹⁾	10 ≤ w ≤ 40	14 ≤ w ≤ 40
Ir192	20 ≤ w ≤ 100	20 ≤ w ≤ 90
Co60	40 ≤ w ≤ 200	60 ≤ w ≤ 150

1) For aluminium and titanium, the penetrated material thickness is 35 mm ≤ w ≤ 120 mm for class A

5.5.5 Film systems and screens

Film system classes and metal screens for radiographic testing of steels, aluminium, copper and nickel based alloys shall be in accordance with recognised standards e.g. ISO 17636/EN 1435.

When using metal screens, good contact between film and screens is required,.

5.5.6 Alignment of beam

The radiation beam shall be directed to the centre of the area being tested and should be perpendicular to the object surface at that point, except when it can be demonstrated that certain imperfections are best revealed by a different alignment of the beam. In this case, an appropriate alignment of the beam may be permitted.

5.5.7 Reduction of scattered radiation

5.5.7.1 Filters and collimators

In order to reduce the effect of back-scattered radiation, direct radiation shall be collimated as much as possible to the section being tested.

With Ir192 and Co60 radiation sources or in the case of edge scatter, a sheet of lead can be used as a low energy scattered radiation filter between the object and the film cassette. The thickness of this sheet shall be between 0.5 mm and 2 mm.

5.5.7.2 Interception of back-scattered radiation

If necessary, the film shall be shielded from back-scattered radiation by an adequate thickness of lead, or of tin, placed behind the film-screen combination.

The presence of back-scattered radiation shall be checked for each new test arrangement by a lead letter “B” placed immediately behind each cassette/film. If the image of this symbol records as a lighter image on the radiograph, it shall be rejected. If the symbol is darker or invisible, the radiograph is acceptable and demonstrates good protection against scattered radiation.

5.5.8 Source to object distance

The minimum source to object distance f_{min} , depends on the source size d and on the film to object distance, b .

The source to object distance f , shall be chosen, where practicable, so that the ratio f/d is in accordance with equations 1) and 2), where b is given in millimetres (mm).

$$\text{For Class A:} \quad \frac{f}{d} \geq 7.5 \left(\frac{b}{\text{mm}} \right)^{\frac{2}{3}} \quad 1)$$

$$\text{For Class B:} \quad \frac{f}{d} \geq 15 \left(\frac{b}{\text{mm}} \right)^{\frac{2}{3}} \quad 2)$$

If the distance $b < 1.2 t$, the dimension b in Equation 1) and 2) and Fig. 5-9 shall be replaced by the nominal

thickness t .

For the determination of the source to object distance, f_{\min} , the nomogram in Fig. 5-9 may be used. The nomograms are based on equations 1) and 2).

In class A, if planar imperfections are to be detected, the minimum distance, f_{\min} shall be the same as for class B in order to reduce the geometric un-sharpness, U_g , by a factor of 2.

For critical technical applications in crack-sensitive materials, more sensitive radiographic techniques than class B shall be used.

When using the elliptical technique described in Fig. 5-2 or the perpendicular technique described in Fig. 5-3, b shall be replaced by the external diameter, D_e , of the pipe in Equations 1) and 2) and in Fig. 5-9.

If the radiation source can be placed inside the object to be radiographed (techniques shown in Fig. 5-2) to achieve a more suitable direction of testing and when a double wall technique (see Fig. 5-4 to 5-6) is avoided, this method should be preferred. The reduction in minimum source to object distance should not be greater than 20%. When the source is located centrally inside the object and the film (see Fig. 5-7) and provided that the IQI requirements are met, this percentage may be increased. However, the reduction in minimum source to object distance shall be no greater than 50%.

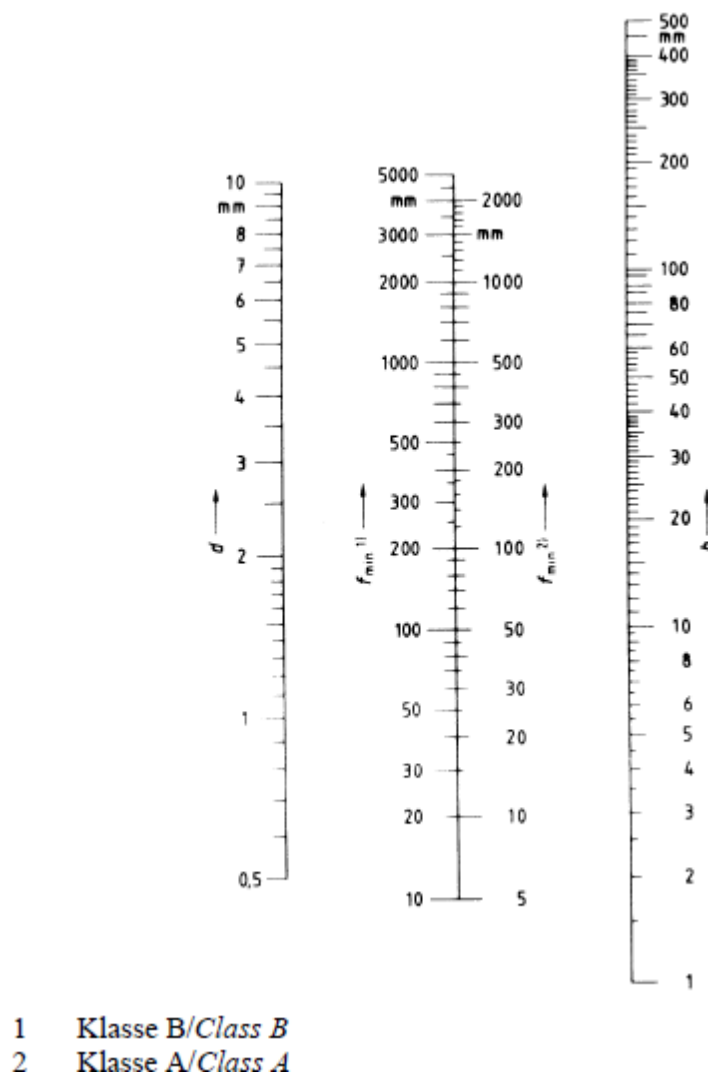

Figure 5-9

Nomogram for the determination of minimum “source to object distance”, f_{\min} , in relation to “object to film distance”, b , and the “source size”, d

5.5.9 Maximum area for a single exposure

The number of radiographs for complete testing of flat welds and of curved welds with the radiation source arranged off-centre should be specified.

The ratio of the penetrated thickness at the outer edge of an evaluated area of uniform thickness to that at the

beam centre shall not be more than 1.2 for class A and 1.1 for class B.

The densities resulting from any variation of penetrated thickness should not be lower than those indicated in 5.5.10 and not higher than those allowed by the available illuminator, provided suitable masking is possible.

The size of the area to be tested includes the welds and the heat affected zones. In general, about 10 mm of parent metal should also be tested on each side of the weld.

5.5.10 Density of radiographs

Exposure conditions should be such that the minimum optical density of the radiograph in the area of interest, see Fig. 5-10, is in accordance with Table 5-9.

<i>Class</i>	<i>Optical density</i> ¹⁾
A	≥ 2.0 ²⁾ to 4.0
B	≥ 2.3 ³⁾ to 4.0

1) A measuring tolerance of ± 0.1 is permitted. For density above 2.5, the minimum luminance through film should be 10cd/m²
 2) May be reduced to 1.8 for x-rays if agreed upon
 3) May be reduced to 2.0 for both x-rays and γ -rays, if agreed upon

The density shall be verified by measuring using an annually calibrated densitometer or by checking the densitometer using a calibrated film strip as reference.

Higher optical densities can be used where the viewing light is sufficiently bright. This to be documented by the manufacturer of the viewing equipment. In order to avoid unduly high fog densities arising from film ageing, development or temperature, the fog density shall be checked periodically on a non-exposed sample taken from the films being used, and handled and processed under the same conditions as the actual exposed radiograph. The fog density shall not exceed 0.3. Fog density here is defined as the total density (emulsion and base) of a processed, unexposed film.

When using a multi-film technique with interpretation of single films, the optical density of each film shall be in accordance with Table 5-9.

If double film viewing is required, the optical density of one single film shall not be lower than 1.3.

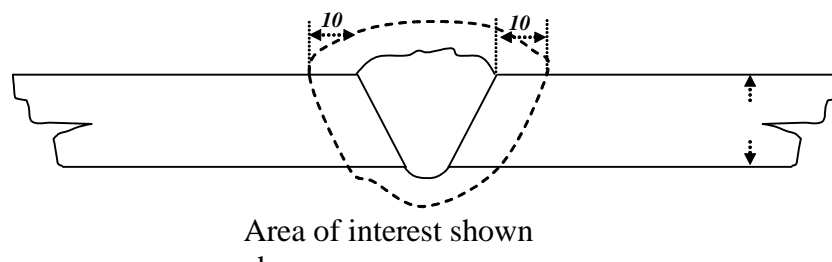

Figure 5-10
Area of interest

5.5.11 Processing

Films should be processed in accordance with the conditions recommended by the film and chemical manufacturer in order to obtain the selected film system class in accordance with international standards e.g. ISO 17636. Particular attention shall be paid to the temperature, developing time and washing time.

5.5.12 Film viewing conditions

The radiographs are to be examined in a darkened area using viewing screens with adjustable luminance in accordance with international standards e.g. ISO 5580. The viewing screens should be masked to the area of interest.

5.5.13 Quality of radiographs

All radiographs shall be free from mechanical, chemical, or other blemishes to the extent that they do not mask the image of any discontinuity in the area of interest of the object being tested.

5.6 Acceptance criteria

Whenever acceptance criteria are defined in the Rules, approved drawings, IACS Recommendations or other agreed product standards, these criteria are mandatory. If no acceptance criteria are defined, acceptance criteria as specified below may be applied.

The quality of welds shall comply with EN-ISO5817 Quality level C, Intermediate. For highly stressed areas more stringent requirements, such as Quality Level B, may be applied.

Table 5-10 Radiographic testing using films

Quality levels in accordance with ISO 5817 or ISO 10042	Testing techniques and levels in accordance with ISO 17636	Acceptance levels in accordance with ISO 10675-1 or ISO 10675-2
B	B	1
C	B ^a	2
D	At least A	3

^a However, the minimum number of exposures for circumferential weld testing may correspond to the requirements of ISO 17636, class A.

For hull and machinery forgings and castings acceptance criteria has to be approved case by case.

5.7 Reporting

In addition to the items listed under 1.11 Final Report, the following have to be included in the radiographic testing report:

- radiographic technique and class
- type and position of image quality indicator
- source to film distance and exposure time
- geometric un-sharpness
- sensitivity
- density
- film, screens and filter
- source type, focus dimension, source activity, used tube voltage and current
- film processing technique: manual or automatic.

6. Ultrasonic Testing

Ultrasonic testing of castings, forgings, weld connections and rolled steel plates.

6.1 Scope

This chapter specifies methods for the manual ultrasonic testing (UT) of fusion welded joints in metallic materials equal to and above 10 mm thickness. It is primarily intended for use on full penetrations welds in C, C-Mn steels, alloy steels and aluminium.

However, techniques for ultrasonic testing of welds in austenitic stainless steel and ferritic-austenitic (duplex) steels are also described.

In addition, methods for manual ultrasonic testing of rolled steel plates, castings and forgings are covered.

The definitions, techniques and requirements specified in this Classification Note will normally satisfy the need for a written procedure. Where this is not the case, or where techniques described in this Classification Note are not applicable to the weld joint or material to be examined, additional written procedures shall be used. The procedures shall be established according to recognised standards and are subjected for approval by the Society.

Typical applications which require specific UT procedures are:

- ultrasonic examination of welds in austenitic stainless steel
- ferritic-austenitic (duplex) stainless steels
- detection of corrosion and/or thickness measurement
- estimation of defect size (height) using conventional beam spread diagram (20 dB-drop) or Time-of-Flight-Diffraction (TOFD) technique

- Phased Array Ultrasonic testing, PAUT
- Automatic Ultrasonic Testing, AUT
- for special application during in-service inspection
- testing of objects with temperature outside the range 0°C to 40°C.

6.2 Definitions and symbols

See 1.3, in addition the following applies:

- *Manual scanning*: Manual displacement of the probe on the scanning surface
- *Amplitude*: Maximum value of the motion or pressure of a sound wave (echo-height)
- *Probe index*: Intersection point of the sound beam axis with the probe surface.
- *Dead zone*: Zone adjacent to the scanning surface within which reflectors of interest are not revealed.
- *DAC*: Distance Amplitude Curve
- *DGS-diagram*: Series of curves which shows relationship between distance along a beam and gain in dB for an infinity reflector and different sizes of disc shaped reflectors.
- *Back wall echo*: Pulse reflected from a boundary surface which is perpendicular to the sound beam axis.
- *6 dB-drop technique*: Method for defect size assessment, where the probe is moved from a position showing maximum reflection amplitude until the echo has decreased to its half-value (by 6dB)
- *Primary Gain*: The gain noted when constructing the DAC using the reference block
- *Corrected Primary Gain*: Primary Gain plus transfer correction
- *dB*: Decibel
- *S*: Skip distance
- *FSH*: Full Screen Height
- *FBH*: Flat Bottom Hole
- *SDH*: Side Drilled Hole.

6.3 Personnel qualifications

Personnel performing testing shall be qualified and certified to an appropriate UT level 2 or 3 in accordance with EN 473, ISO 9712 or other equivalent recognised standard or certification schemes e.g. PCN and NORDTEST. Other recognized national certification schemes may be considered.

Personnel performing ultrasonic testing of welds in austenitic and duplex stainless steel material, shall be specially trained and qualified for the purpose according to EN 473, ISO9712 or other equivalent recognised standard or certification scheme.

The certificate shall state qualifications as to which application/joint-figuration the operator is qualified.

6.4 Requirements to equipment

6.4.1 Ultrasonic Apparatus

The apparatus is to:

- be applicable for the pulse-echo technique and for the double-probe technique
- cover a minimum frequency range from 1 to 6 MHz
- have a calibrated gain regulator with minimum 2 dB per step over a range of minimum 60 dB
- be equipped with a flat screen accessible from the front for direct plotting of Distance Amplitude Curves (DAC) or be equipped with digital DAC- display presentation
- be able to clearly distinguish echoes with amplitudes of 5% of full screen height.

Each ultrasonic apparatus shall have a calibration certificate with reference to the apparatus serial number. This calibration of the apparatus shall be performed by a company approved by the apparatus manufacturer. The calibration is valid for a maximum of one year. The ultrasonic apparatus serial number shall be included in the examination report.

6.4.2 Probes

Probes used for testing of welds in C, C-Mn steels and alloy steels shall be straight beam transducers and angle shear-wave transducers of 45°, 60° and 70°.

Probes used for testing of welds in austenitic and austenitic-ferritic (duplex) steel shall be straight beam transducers and twin crystal (transmitter/receiver) compression-wave transducers of 45°, 60° and 70°. In addition and as a combination also similar shear-wave angle probes (see 6.7.3 and 6.7.10) and creep-wave probes are to be used.

Also other angle probes may be used, see 6.6.8 “Testing of weld connections – General”

Probes used for testing of rolled steel plates shall be straight beam transducers, single- or twin crystal.

Probes used for testing of castings and forgings shall be straight beam transducers, single- or twin crystal and angle shear wave transducers.

6.4.3 Adaptation of probes to curved scanning surfaces

The gap between the test surface and the bottom of the probe shoe shall not be greater than 0.5 mm. For cylindrical or spherical surfaces the requirement will normally be met when the following equation is fulfilled:

$$D \geq 15 A$$

where:

D = the diameter in millimetres of the component

A = the dimension in millimetres of the probe shoe in the direction of scanning.

If this requirement can not be obtained the probe shoe shall be adapted to the surface and the sensitivity and range shall be set accordingly.

6.4.4 Coupling medium

Satisfactory coupling medium, in either fluid or paste form, is to be used to transfer the ultrasound from the probe to the surface of examination object.

Oil, grease, glycerine or paste is well suited for this purpose.

The coupling medium used for calibration shall also be used during testing. During retesting / verification old glue to be removed before testing, if not otherwise qualified due to increased attenuation.

6.4.5 Calibration blocks

The IIW or ISO calibration blocks (K1 – K2), see Fig. 6-1, shall be used for calibration of range scale and for angle determination. These calibration blocks shall preferably have the same acoustic properties as the material to be tested.

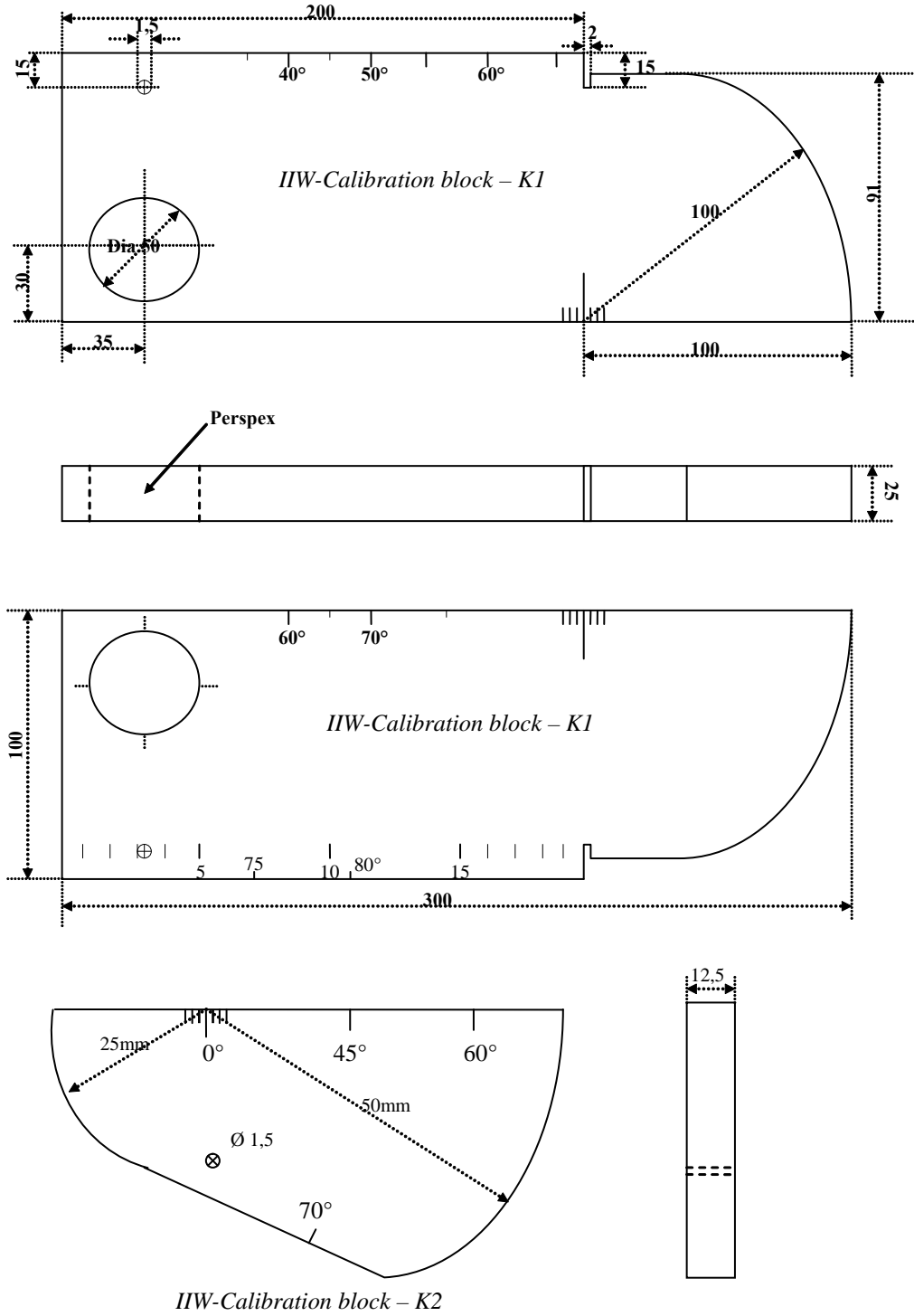

Figure 6-1
Calibration blocks

6.4.6 Reference blocks for calibration of amplification for testing of welds

Reference blocks shall be made with thickness and side-drilled holes, as described in Table 6-1 and shown in Fig. 6-2, and shall be used for amplification (gain) calibration and construction of reference (DAC) curves. The

reference block shall normally be manufactured from the actual material tested and have approved dimensions. When ultrasonic testing is to be performed on steel produced by controlled rolling or thermo mechanical treatment (TMCP steel), reference blocks shall be produced both perpendicular to, and parallel to, the direction of rolling. The rolling direction shall be clearly identified, see also 6.6.4, for more detailed information see appendix A.

Ultrasonic testing of welds in austenitic and austenitic-ferritic (duplex) steel requires additional reference blocks to those described in Table 6-1, see 6.7.6.

Table 6-1 Reference block requirements			
<i>Thickness of material to be examined (mm)</i>	<i>Thickness of block (mm)</i>	<i>Diameter of hole (mm)</i>	<i>Distance of hole from one surface (mm)</i>
10 < t ≤ 50	40 or T	Ø 3 ± 0.2	T/2 and T/4. Additional holes are allowed and recommended
50 < t ≤ 100	75 or T		
100 < t ≤ 150	125 or T	Ø 6 ± 0.2	
150 < t ≤ 200	175 or T		
200 < t ≤ 250	225 or T		
t > 250	275 or T		

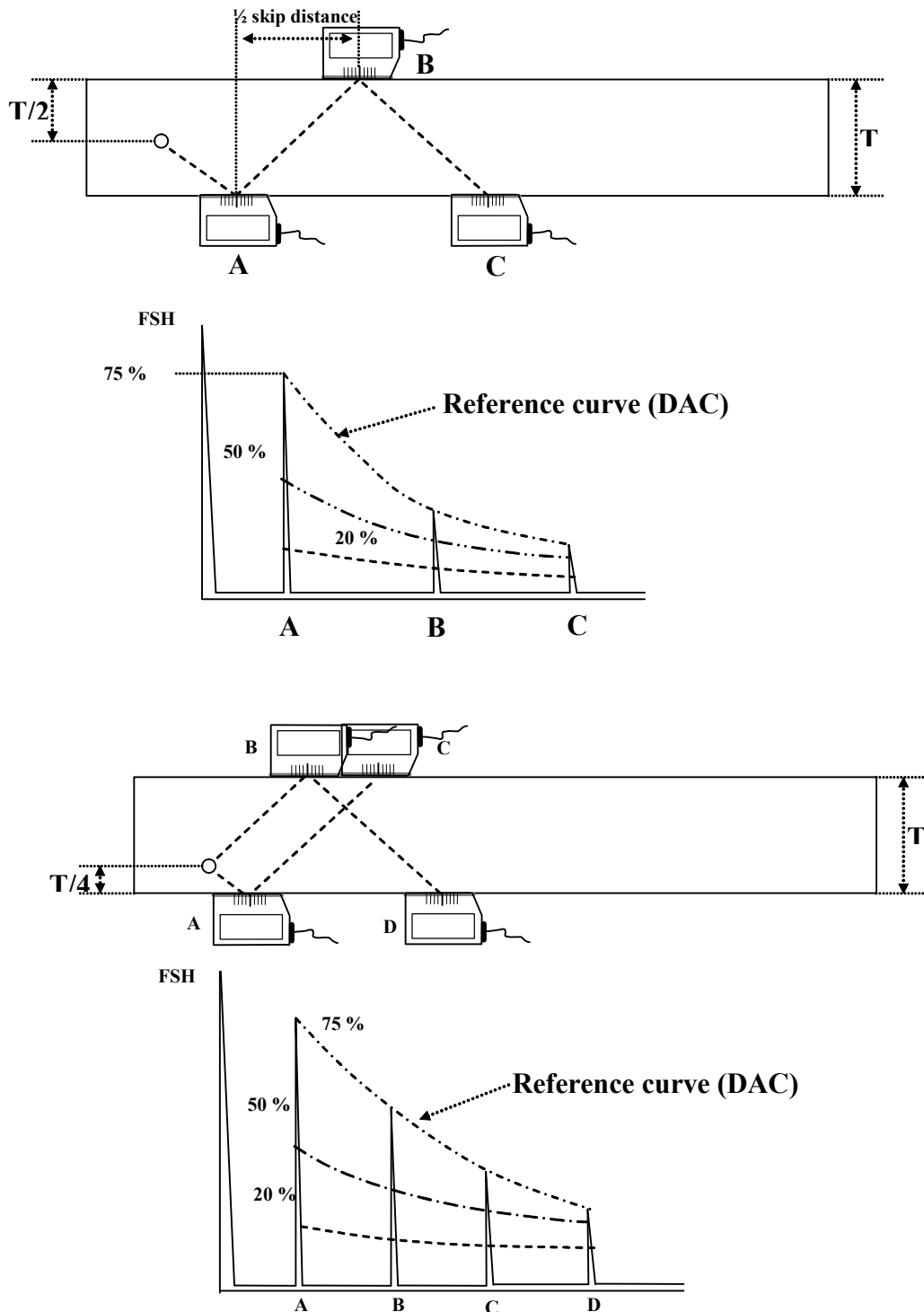

Figure 6-2
Reference blocks

6.4.7 Periodically check of equipment

Calibration of ultrasonic equipment shall be undertaken according to procedures established according to recognised code or standard, e.g. EN 12668-1-2-3 or ASME V.

Records shall be filed by owner.

Verification of Screen Height Linearity and Amplitude Linearity shall be performed at the beginning of each period of extended use (or every 3 months, whichever is less).

At approximately four-hourly intervals the range scale, probe angle and primary gain must be checked and corrected. Checks shall also be carried out whenever a system parameter is changed or changes in the

equivalent settings are suspected.

If deviation is found to be $> 2\%$ of range scale, > 4 dB of primary gain setting or $> 2^\circ$ of nominal angle probe, the examinations carried out with the equipment over the previous period shall be repeated.

6.5 Preparation of scanning surfaces

For ultrasonic testing the contact surface shall be clean and smooth, i.e. free from dirt, scale, rust, welding spatter, “old” glue/ couplant etc. which may influence the results of the testing.

6.6 Testing volume

6.6.1 Welds in C, C-Mn steels, alloy steels and aluminium

The testing volume is defined as the zone which includes weld and parent material for at least 10 mm on each side of the weld, or the width of the heat affected zone (HAZ), whichever is greater.

The parent metal, in the scanning zone for angle probes, shall be tested with straight beam (normal) probes. The scanning zone is defined as $1.5 \times$ full skip distance (S), see Fig. 6-11.

Scanning of parent material is performed in order to reveal laminations, imperfections, large variations in attenuation or thickness variation, which might influence the angle beam testing.

The welds shall whenever feasible be tested from both sides on the same surface and include scanning for both transverse and longitudinal indications. For T-joints and plate thickness above 40 mm, scanning from both surfaces and all accessible sides shall be performed.

Where configuration or adjacent parts of the object are such that scanning from both sides is not possible this fact shall be included in the report.

Use of multiple angle probes scanning in addition to normal probe scanning is required.

Evaluation of defects is primarily to be based on echo amplitude reflected from the revealed indications.

The indications shall be investigated by maximising the echoes with different angle probes and by rotating the probes. For evaluation of defects the evaluation level (-10 dB (33% of DAC)) or as stated in the acceptance criteria as agreed shall be used, ref. EN ISO 11666.

6.6.2 Calibration

6.6.2.1 Calibration of range scale with straight beam probe

The calibration of range scale with straight beam probe is to be carried out with an IIW calibration block, a K2 calibration block or on a defect free area of the material to be tested.

The range scale is to be selected such that there are always at least 2 back-wall echoes (reflections) on the screen.

Fig. 6-3 shows typical calibration in range 0-100 mm, 0-200 mm and 0-500 mm for straight beam probes.

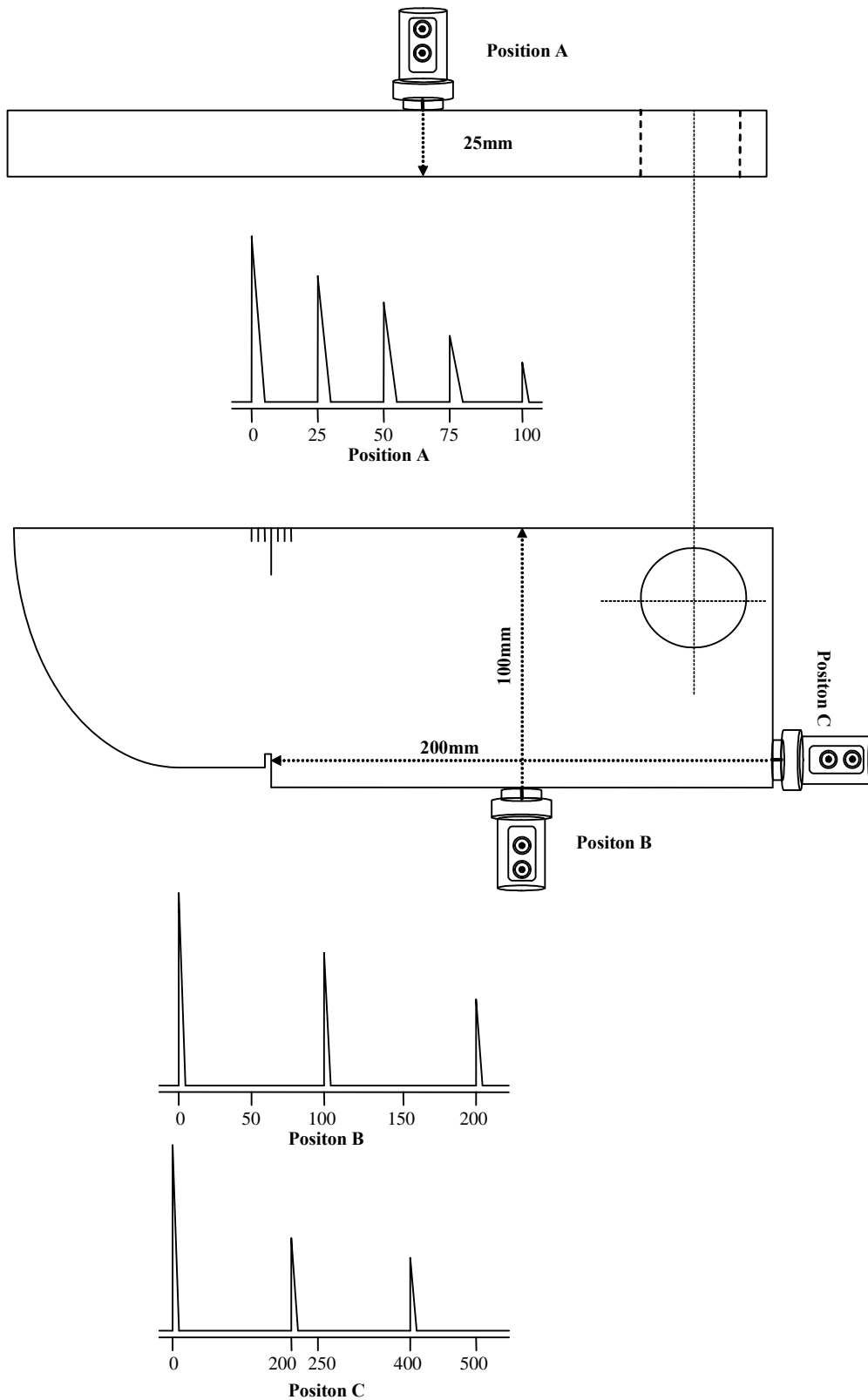

Figure 6-3
Calibration of range with straight beam normal probe

The calibration of angle beam probes is to be carried out on an IIW or K2 calibration block. The range is to be selected in order to cover minimum $1.5 \times$ full skip distance.

Required skip distance (S) is depending of the object thickness and can be calculated as follows:

$$S = 2 T \tan \alpha$$

where

T = Thickness of object to be tested

α = probe angle.

6.6.2.2 Calibration of range scale for twin crystal straight beam probe

Two thicknesses, preferably with thickness a little above and below the thickness to be tested must be used to reduce the measuring error due to the angled crystals in this type of probe.

The calibration of the range scale with twin crystal straight beam probe shall therefore be carried out with a step calibration block, see sketch below or the 25 mm thickness on the K1 in combination with the 12.5 mm thickness on the K2 calibration blocks.

Only the first back wall echo shall be used when calibrating the range scale with twin crystal normal probe.

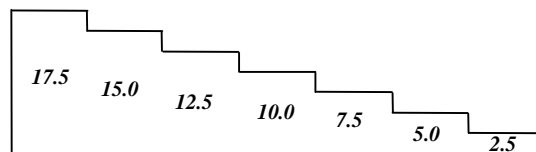

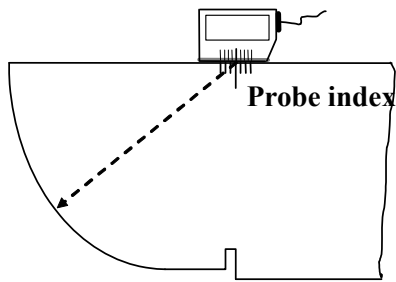

Fig. a

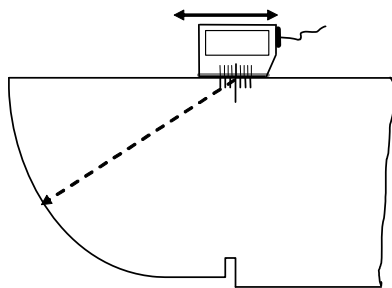

Fig. b

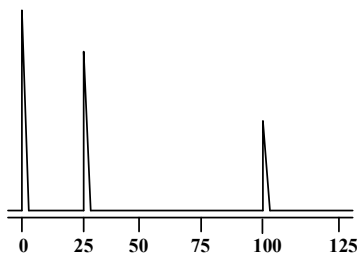
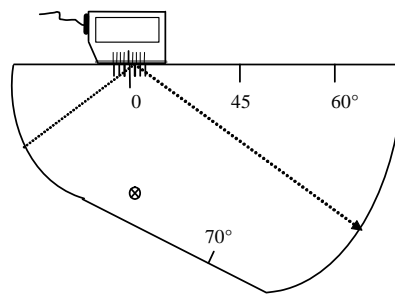
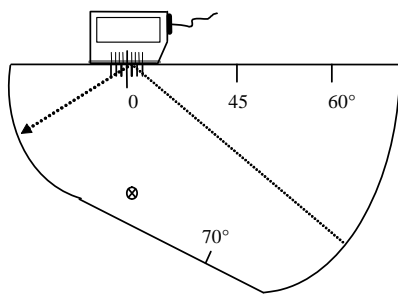
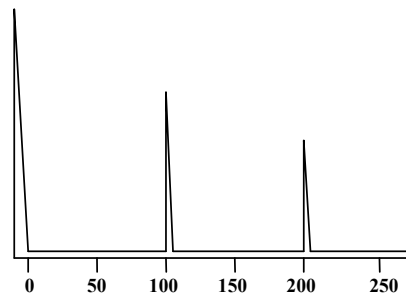

Fig. c

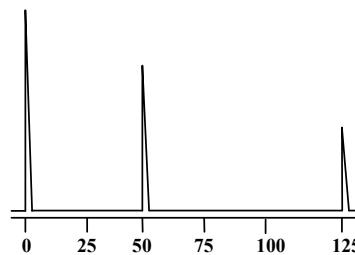

Figure 6-4
Fig. a, b and c show determination of probe index and calibration of range with angle probe

6.6.3 Determination of probe angle

The probe index is to be determined by placing the probe as shown in Fig. 6-4a and by maximising the echo against the cylinder surface with radius 100 mm (IIW) or 50 mm (K2), the echo height is adjusted to about 75% of full screen height. The probe index can now be read off against the mark on the calibration block and marked off on the probe.

The probe angle is to be checked on the IIW block using the index found. The echo from the circular Perspex reflector is maximised and put at 75% of full screen height. The probe angle can now be read off on the calibration block against the engraved centre point, see Fig. 6-5.

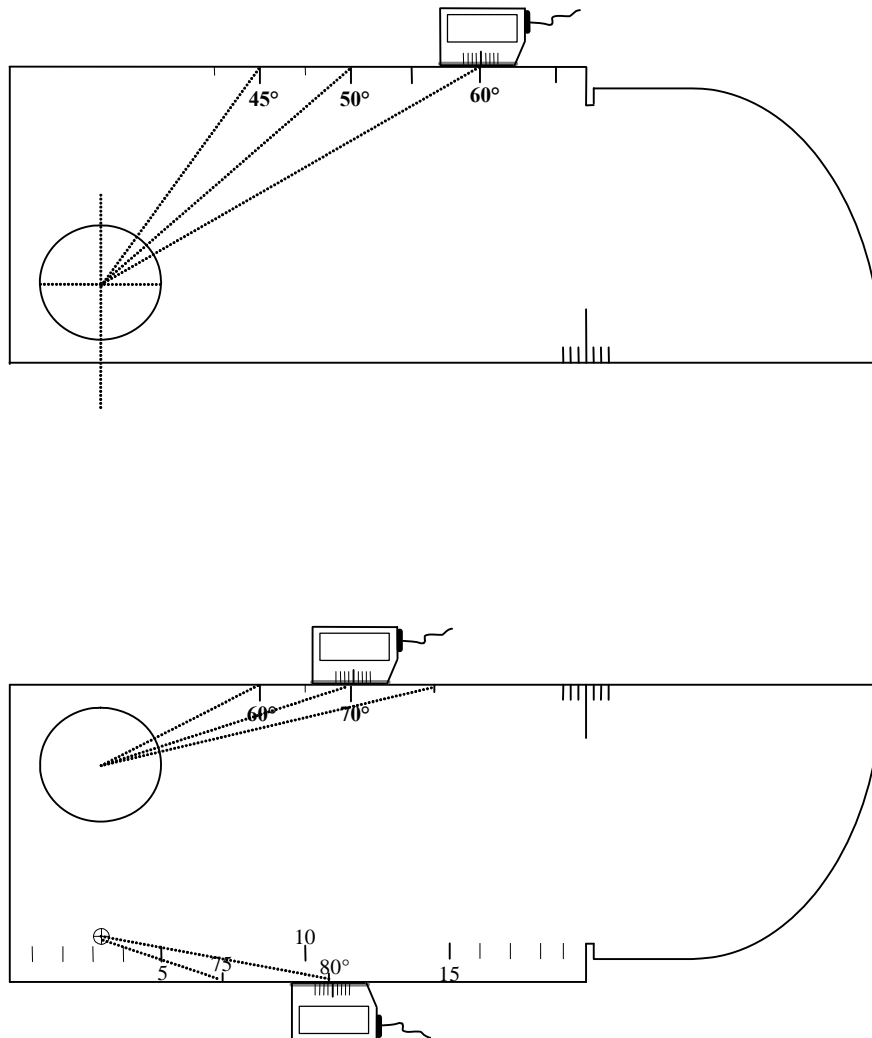

Figure 6-5
Checking the probe angle

6.6.4 Calibration of amplification

Calibration of the amplification shall include the whole of the ultrasonic system, which are the ultrasonic apparatus, probes, cables and coupling medium.

In order to compensate for attenuation and sound beam spread with increasing sound path a DAC- curve, which gives the echo height from the same reflector at varying distance between probe and reflector, is to be constructed.

DAC is to be constructed using reference blocks with side-drilled holes as described in 6.4.6.

The reference blocks shall preferably have the same acoustic properties as the material to be tested. If this is not obtained correction for deviation in sound velocity between the calibration block and the object to be tested must be made. Any deviation can be checked by calibrating the range scale on the IIW block with a normal probe and subsequently measure a known material thickness with this calibration.

Whenever ultrasonic testing is performed of welds in TMCP steel the following must be verified:

Difference in attenuation between transverse and longitudinal rolling direction is to be checked when the scanning changes from transverse to longitudinal of rolling direction or inverse.

This requires DAC- curves constructed by use of calibration blocks in both transverse and longitudinal rolling direction. Difference in gain setting must be noted and taken into consideration when evaluation of imperfections is performed.

The nominal angle of probes used are normally valid for C, C-Mn steels and alloy steel with compression wave velocity of approximately 5 900 m/s and shear wave velocity of approximately 3 200 m/s.

When examination is to be carried out of welds in TMCP steel and aluminium the actual beam angle must be determined. The angle can be calculated using trigonometric functions as long as the distance and depth to the reflectors in the TMCP steel or aluminium calibration block is known. See more information regarding TMCP in appendix A

6.6.5 Construction of reference curve, DAC

Angle probes:

The echo reflected from the drilled hole in the reference block, see 6.4.6, is maximised and the gain control regulated so that the echo amplitude is 75% of full screen height (FSH).

This gain setting is called the primary gain and is to be noted. Without altering the primary gain, the probe is positioned in various skip distances as indicated on Fig. 6-2 and the respective echo amplitudes are marked on the screen.

These points are connected with a smooth line with a length, which covers the required scanning area. This is the reference curve (DAC).

The first point of DAC must be selected so that the distance in sound path from the probe index to the drilled hole is not less than $0.6N$ where N is the near field length of the relevant probe.

When DAC has been set up it is recommended to draw two additional curves, 33% and 50% of DAC, on the screen. Where DAC by excessive sound paths falls to below 25% of FSH the gain in this area is to be increased and a new DAC must be established, see Fig. 6-6.

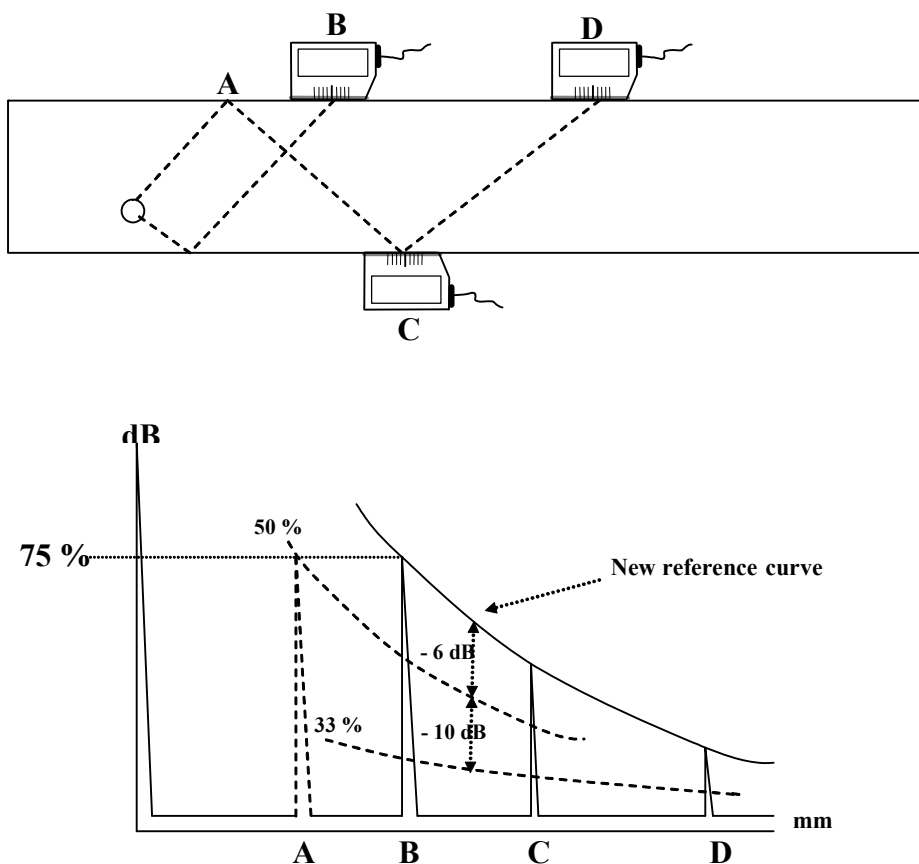

Figure 6-6
Increase of gain at excessive sound path

If the ultrasonic apparatus is fitted with a time corrected gain (TCG) correction, this can be used for angle and straight beam probes. The echo amplitude reflected from the drilled hole in the calibration can be adjusted to 75% of full screen height over the whole of the range in question. DAC will thus be a horizontal line. The gain setting is noted and comprises the primary gain.

Straight beam probes:

For testing of weld connections using straight beam probes the side drilled hole (SDH) in the reference block is to be used for gain setting as for the angle probes. In order to have relevant DAC, the curve must be established as indicated on Fig. 6-7.

Fig. 6-7 indicates calibration on two different reference blocks. See also Table 6-1.

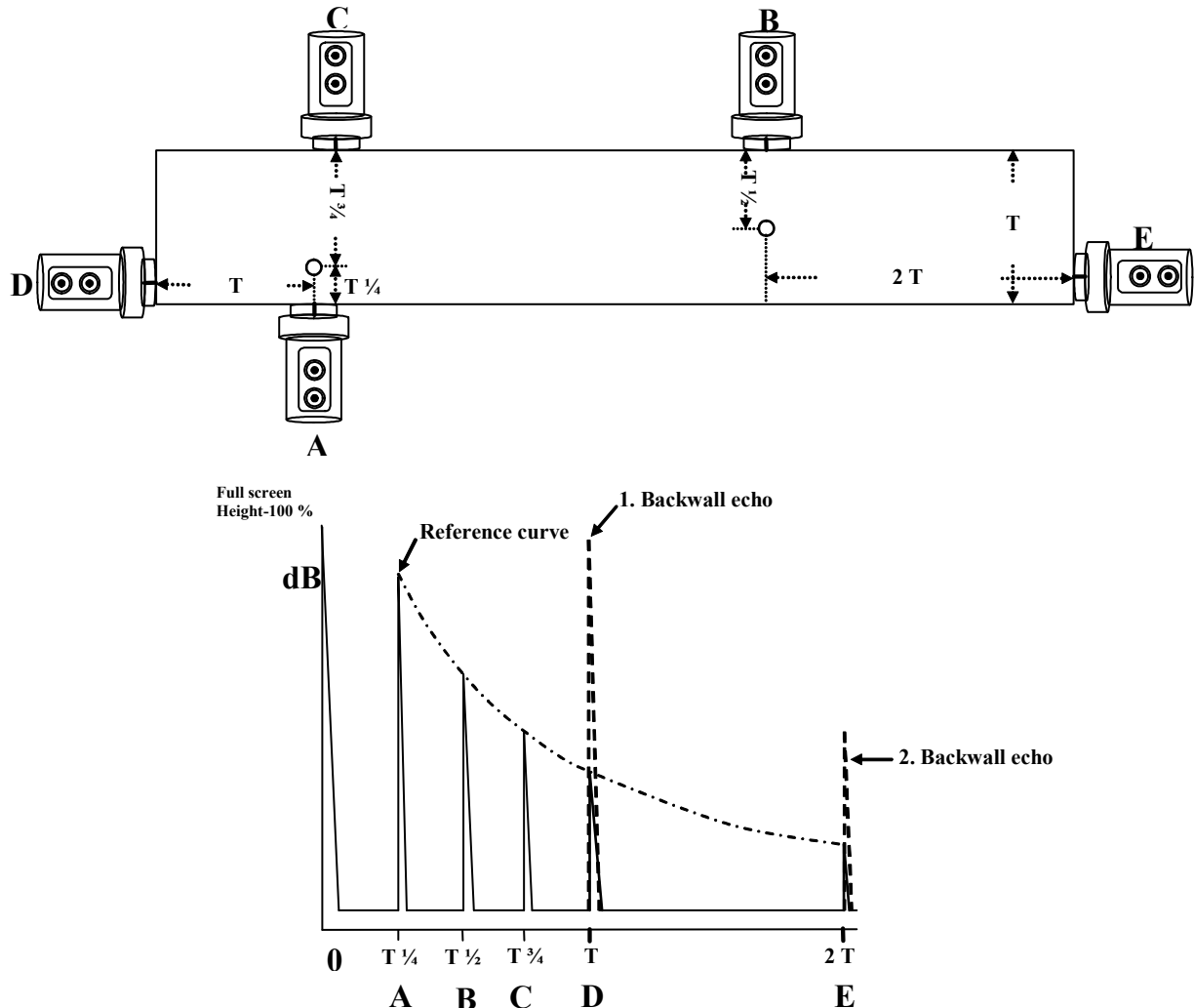

Figure 6-7
Calibration of gain with straight beam probes

6.6.6 Transfer correction

Any possible difference in attenuation and surface character between the reference block and the object to be tested are to be checked in the following way: Two angle probes of the same type as those to be utilized during the testing are to be used. The probes are placed on the object to be tested as shown on Fig. 6-8. One of the probes works as transmitter probe, whilst the other acts as receiver. The first echo is maximised and with the aid of the gain control it is adjusted to reach DAC. The gain setting is noted. Without altering this gain setting the probes are moved to the reference block. The echo is adjusted to reach DAC and the gain setting is noted.

Any difference in echo amplitude between the two materials can now be determined with the aid of the gain control.

If the differences are less than 2 dB, correction is not required.

If the differences are greater than 2 dB but smaller than 12 dB, they shall be compensated for.

If transfer losses exceed 12 dB, the reason shall be considered and further preparation of the scanning surfaces

shall be carried out, if applicable.

When there are no apparent reasons for high correction values, the attenuation, at various locations on the test object shall be measured. Where it is found to vary significantly, corrective actions must be considered.

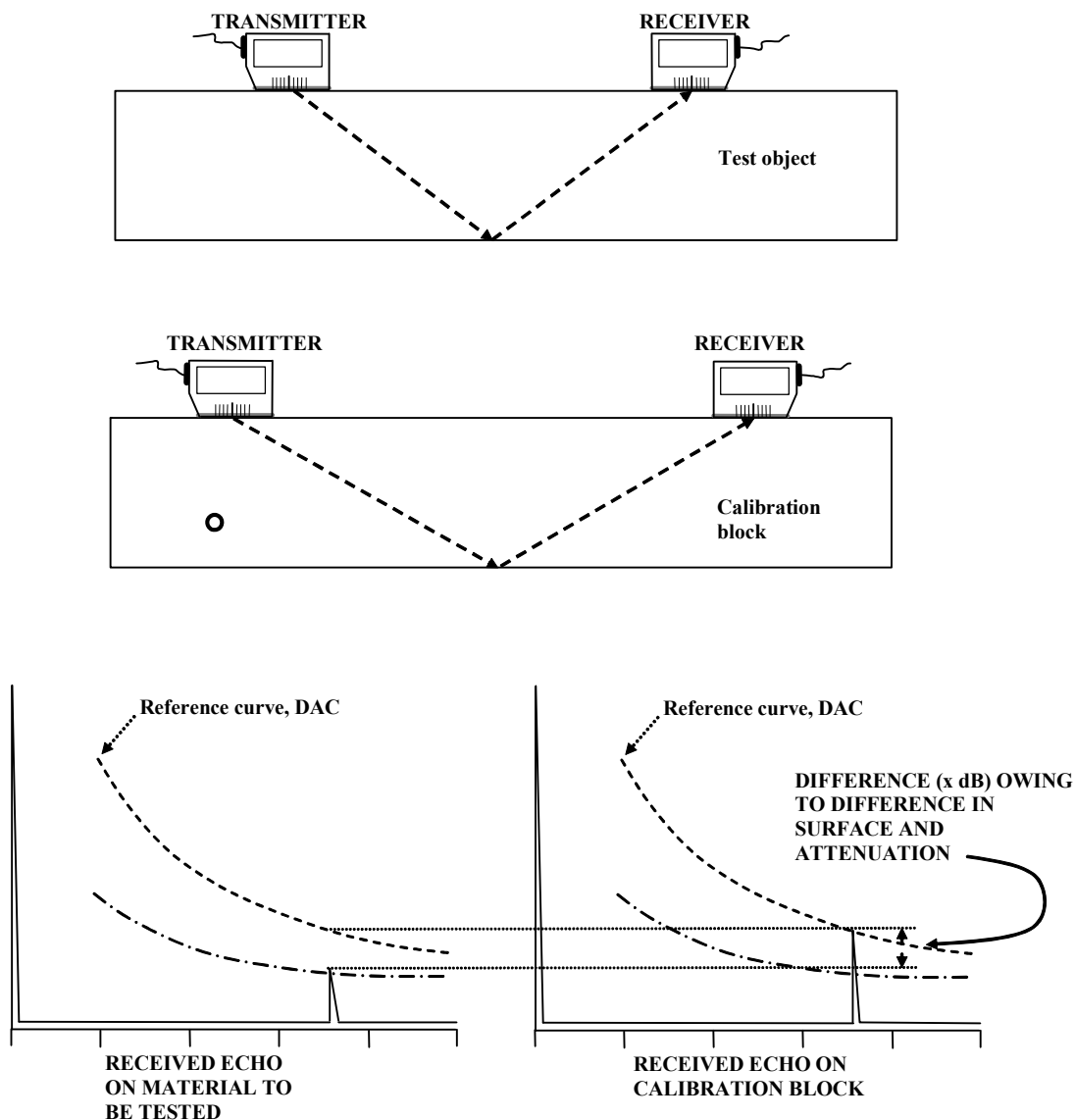

Figure 6-8
Attenuation and surface correction

6.6.7 Testing of parent material

The examination is to be performed in order to reveal possible imperfections, which might influence the angle probe testing.

The whole of the area ($1.5 \times S$) which will transfer ultrasound when using angle probes shall be tested. The gain setting shall be calibrated on a defect free place on the parent material. The second back wall echo shall be set to 75% of FSH Imperfections with a cross section larger than the sound beam (loss of back wall echo) shall be reported. The extent of the imperfections is measured with the aid of the 6 dB-drop method when complete loss of back wall echo occurs.

See also 6.11 Ultrasonic testing of rolled steel plates

For acceptance criteria, see 6.11.7.

6.6.8 Testing of weld connections - General

Testing of weld connections is to be undertaken for the purpose of revealing possible:

- Imperfections in the parent metal and in the transition between weld and parent metal.

— Imperfections in the weld metal and HAZ.

In addition to straight beam probe angle probes shall be used for the testing, see Table 6-2.

Choice of angle probes is depending on material thickness, weld bevel and type of defect being sought.

When reference is made to Pt.2 Ch.3, minimum angle probes to be applied shall be in accordance with ISO 17640, if not minimum two angle probes is applied, see table 6.2

For reference to OS-C401, minimum two angle probes shall be applied.

The following angle probes are recommended to be used:

Parent material thickness, <i>T</i>	Probe angle
10 to 15 mm	60° and 70°
15 to 40 mm	45° and 60° or 70° (70° when ½ V or K groove)
<i>T</i> > 40 mm	45° and 60° or 70° (70° when ½ V or K groove)

A favourable probe angle when the weld connections is being tested for lack of fusion in the transition between weld and parent material is the angle which gives incident sound normal to the angle of the weld bevel. The optimal angle for a V-groove is given by the groove geometry and can be calculated as shown in Fig. 6-9. If the calculated angle does not comply with any standard probe angle, the nearest larger probe angle shall be selected. When use of two or more angle probes is specified, the difference between the nominal beam angles shall be 10° or greater, ref. EN1714 Ch. 6.3.2/ISO17640 and ASME V Art.4 Appendix I-471.

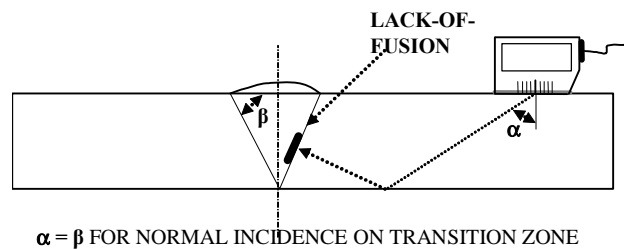

Figure 6-9
Detection of side wall lack of fusion

The gain which is to be used in the evaluation of the imperfection is the primary gain.

When scanning, the gain is to be the corrected primary gain plus 6 dB in order to increase the sensitivity to defects with a difficult orientation. The gain must then be reduced to the corrected primary dB level when defect evaluation is carried out. The evaluation level stated in the acceptance criteria such like -10 dB (33%) of DAC shall be used.

For evaluation of defects, the evaluation curve shall be used.

The length of the imperfections is to be evaluated by maximising the echo amplitude in the middle of the defect. Subsequently, the probe is traversed towards the edge of the imperfection until the echo amplitude has dropped to the evaluation level -10 dB (33% of DAC) The centre of the probe is then marked off as the edge of the imperfection, see Fig. 6-10.

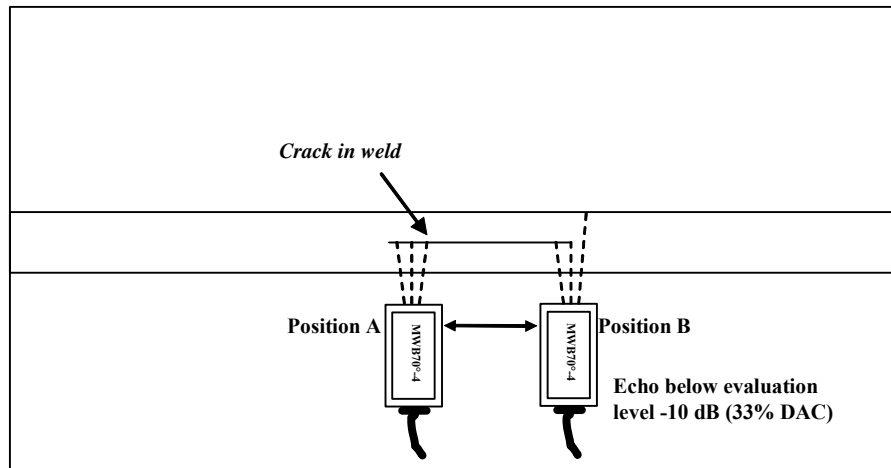

Figure 6-10
Evaluation of length of the defect

6.6.8.1 Testing of butt welds

6.6.8.1.1 Use of angle probes for detection of longitudinal imperfections

Where possible the welds are to be tested from one surface of the plate and from both sides of the weld connection. The angle probe is placed on the parent material in such a way that the sound beam is normal to the weld. The probe is to be moved forwards and backwards in the scanning area of $1.5 \times S$.

During this movement the probe is to be continuously turned 5 to 10° in the horizontal plane, as intimated on Fig. 6-11. For plate thickness greater than 40 mm it shall be tested from all accessible side and surfaces (4) of the weld.

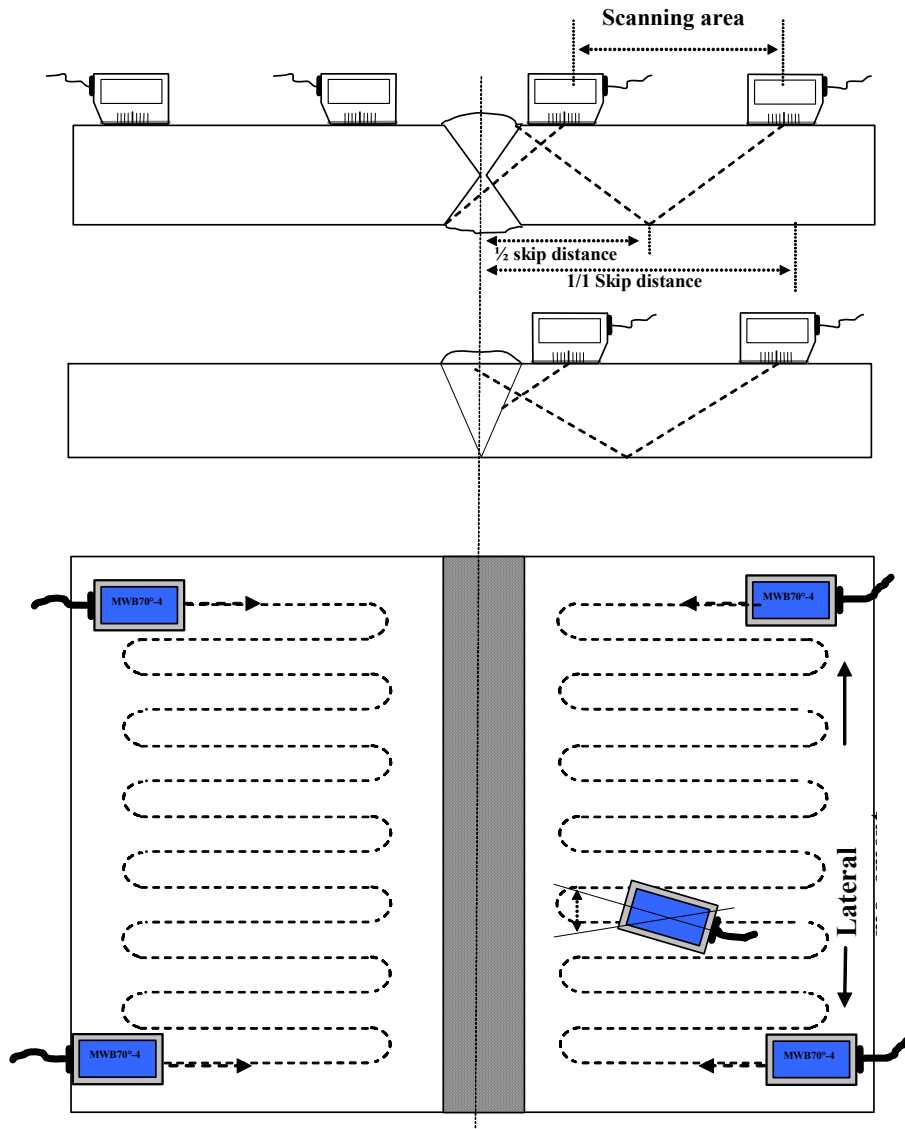

Figure 6-11
Probe movement for testing of butt welds - for x-groove and v-groove

The double probe (tandem) technique can be used for the detection of imperfections with the reflection normal to the surface, see Fig. 6-12. Two separate angle probes are used, and the most favourable sound beam angle, which covers the area in question, is selected. For this type of testing it is recommended to make a holder for the probes, so that the distance A between the probes is kept constant. The probe combination is moved along the weld connection in the distance B from the centreline.

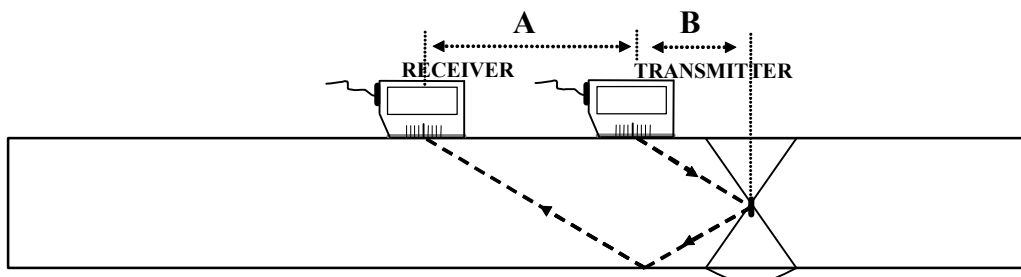

Figure 6-12
Double probe technique

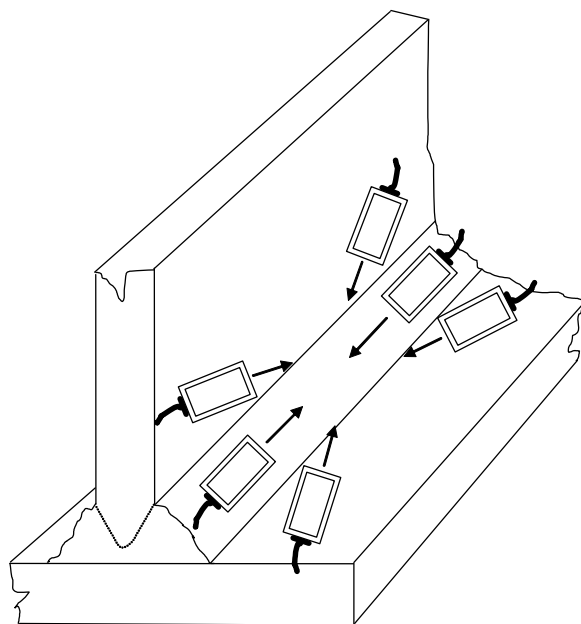
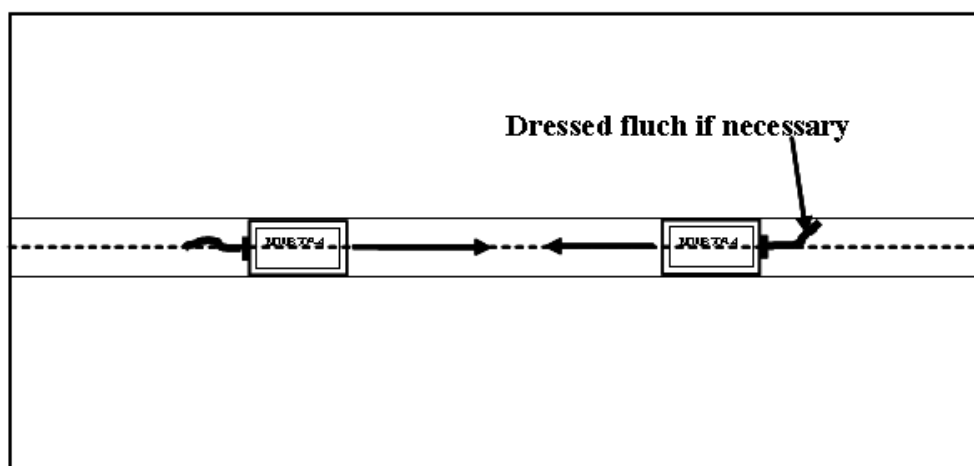
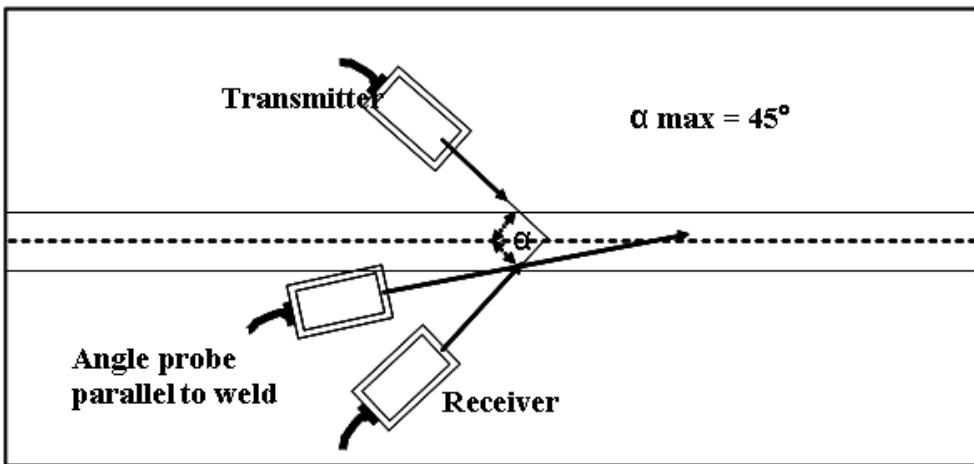

Figure 6-13
Fig. a and b show detection of transverse defects; Fig. c shows detection of transverse defects in T-joints

6.6.8.1.2 Use of angle probes for detection of transverse imperfections

Transverse imperfections can be detected by placing the probe on the surface along the centre line of the weld connection provided the surface finish is sufficient smooth. Alternatively the probe can be placed alongside the weld connection, so that the beam forms a small angle with the centreline, see Fig. 6-13a. Another method using two separate probes is shown in the same figure (double probe technique).

If using an angle probe along the centre line of the weld is judged to be the only method of reliable examination, the weld cap is to be ground flush or smooth with the parent material, see Fig. 6-13b. The probe is then moved along the centreline, so that the entire weld is covered.

Scanning is in all cases to be performed from both sides of the weld and in both directions.

6.6.8.1.3 Use of straight beam probes for detection of weld imperfections:

Weld imperfections with a reflection surface parallel to the scanning surface can be detected with a normal probe. The probe is placed on the weld and moved along and across the weld connection so that the whole joint is examined. The weld should preferably be ground flush.

6.6.8.2 Testing of T-joints

Examination of T-joints with 1/2V or K-groove is carried out as for butt welds. The scanning area for the probes is shown in Fig. 6-14.

Testing of nodes to be performed in accordance with API RP 2X.

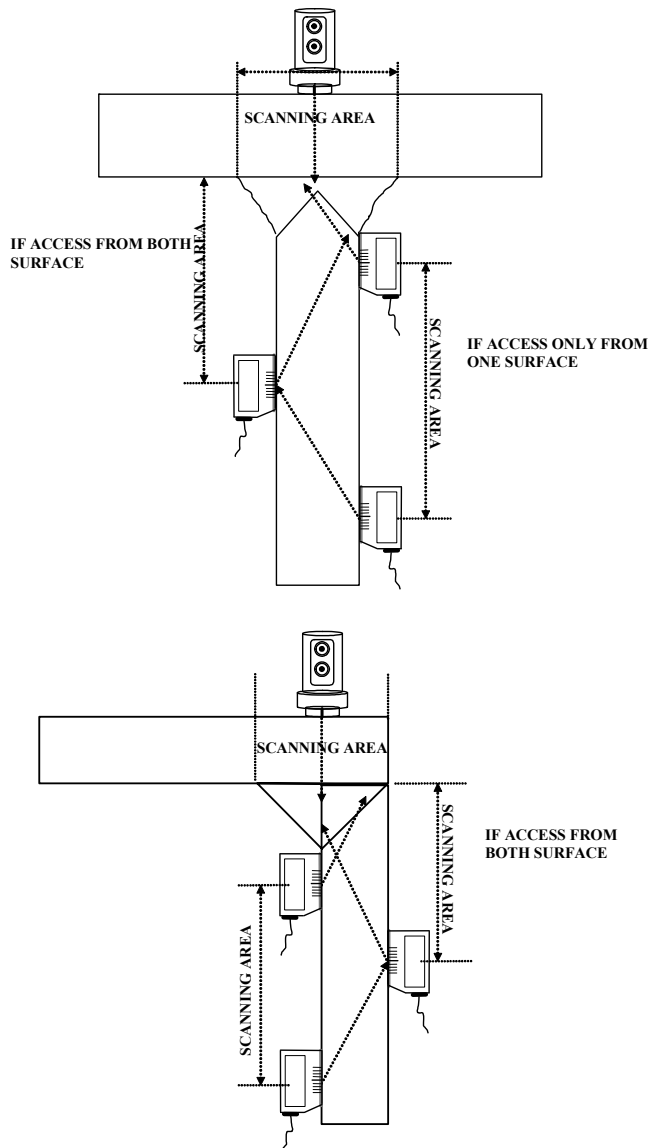

Figure 6-14
Inspection of T-or corner joints (single-bevel or double-bevel groove welds)

6.7 Welds in austenitic stainless and ferritic-austenitic (duplex) stainless steel

6.7.1 General

Ultrasonic testing of welds in austenitic stainless steel and ferritic-austenitic stainless steel requires special equipment especially in the area of reference blocks and probes to be used.

Due to the coarse grain structure of the material and the weld metal in particular a probe, which generates compression waves at angles, must be used in addition to straight beam - and angle shear wave probes. Physical properties of stainless steels results in a variation of grain size and structure which entails variation in attenuation and imperfection detectability.

The testing must be carried out in accordance with specific developed written UT- procedures for the item in question or procedure qualification if found necessary and shall be approved by the Society.

6.7.2 Personnel qualifications

For personnel qualifications see 6.3.

6.7.3 Probes

For selection of probes, see 6.4.2.

It must be verified using reference blocks with actual weld connections, see 6.7.6 whether angle shear wave probes are suitable.

In general, a combination using both shear and compression wave angle probes is recommended in addition to straight beam (normal (0°)) and creep wave probes.

The detectability of “open to surface” imperfections like incomplete penetration and lack of fusion may increase using shear wave probes. Sub surface defects closed to the scanning surface are to be detected by use of creep wave probes.

6.7.4 Adaptation of probes to curved scanning surfaces

See 6.4.3

6.7.5 Coupling medium

See 6.4.4

6.7.6 Calibration blocks for calibration of amplification

The basic calibration blocks described in 6.4.5 are to be used.

In addition reference blocks, prepared from test material, containing welds produced in accordance with the actual WPS are to be used for establishing of DAC. These reference blocks must have drilled holes (\varnothing 3 mm or \varnothing 6 mm depending of thickness) positioned in depths of $1/4 T$, $1/2 T$ and $3/4 T$. The drilled holes (reflectors) must be located as shown in Fig. 6-15.

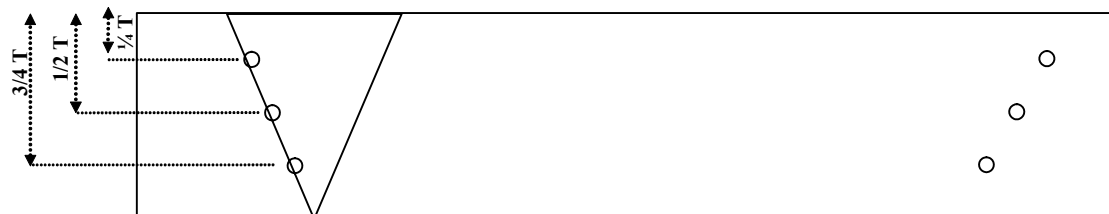

Reference block for ultrasonic examination of welds in austenitic and austenitic-ferritic steel.

Figure 6-15

Reference block for ultrasonic examination of welds in austenitic and austenitic-ferritic steel

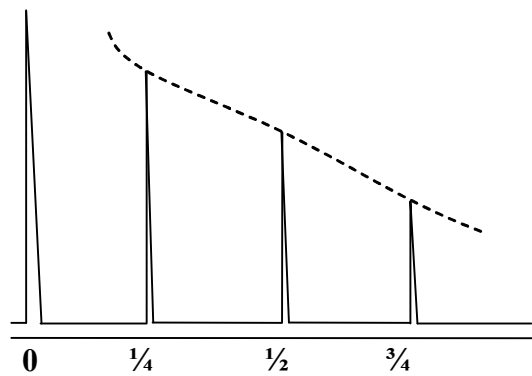
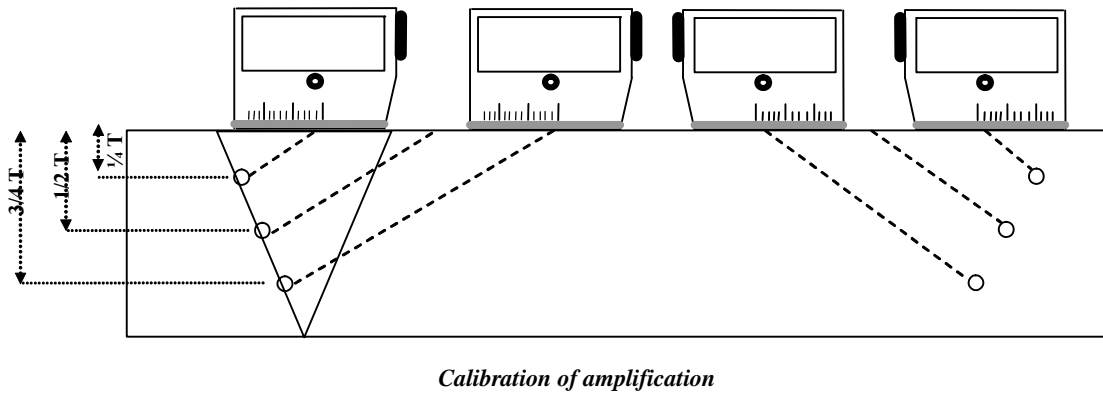

Figure 6-16
Calibration of amplification

Guidance note:

Reflector holes are to be drilled in both fusion lines whenever two dissimilar materials are welded to each other.

---e-n-d---of---G-u-i-d-a-n-c-e---n-o-t-e---

Reference blocks for creep wave probes must contain 0.5, 1.0 and 2.0 mm spark eroded notches at the scanning surfaces, See Fig. 6-17.

The surface condition of the reference blocks is to be similar to the condition of the parent material to be examined (scanned).

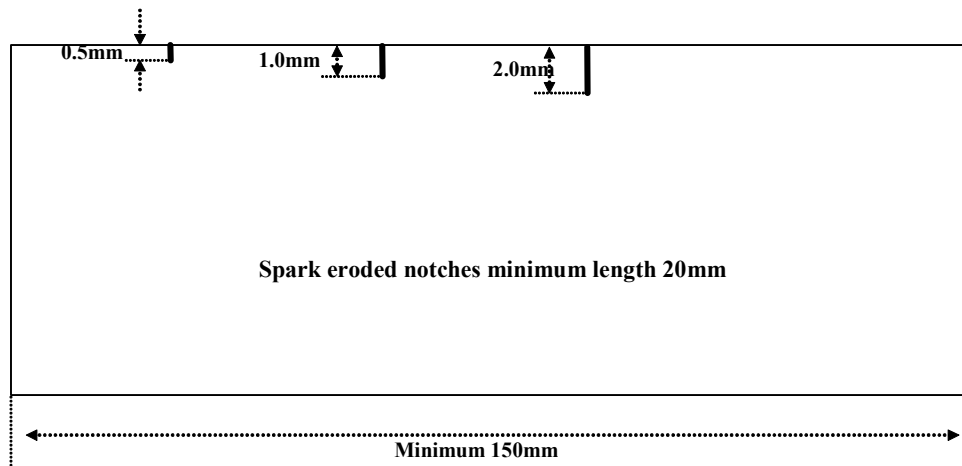

Figure 6-17
Reference block for creep wave probe

6.7.7 Preparation of scanning surfaces

See 6.5.

6.7.8 Testing volume

See 6.6.1.

6.7.9 Calibration

6.7.9.1 Calibration of range scale

Calibration of range is to be carried out with the use of a duplex K2 block as indicated in Fig. 6-18. See also 6.6.2.

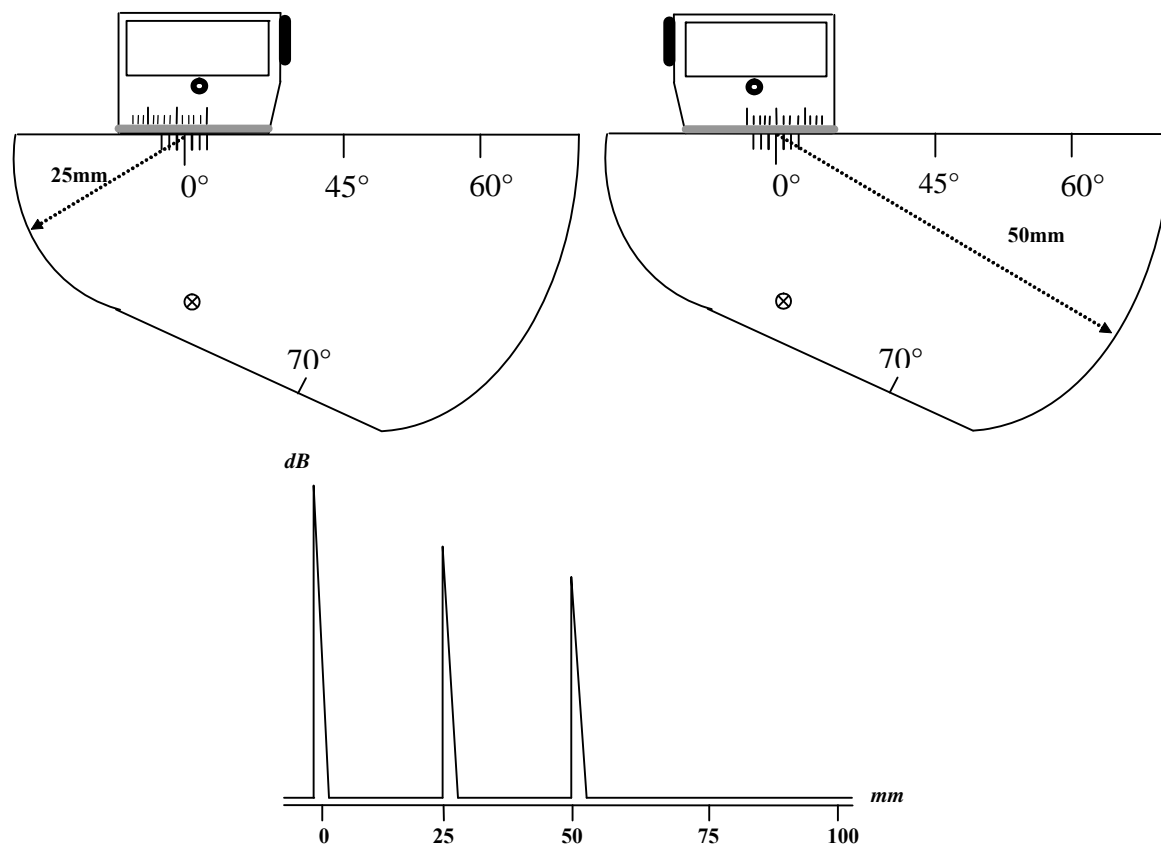

Figure 6-18
Calibration of range for duplex K2 block

Guidance note:

Angle compression wave probes can only be used for $\frac{1}{2}$ skip (S) scanning.

---e-n-d---of---G-u-i-d-a-n-c-e---n-o-t-e---

6.7.9.2 Control of probe angle

See 6.6.3.

6.7.10 Calibration of amplification and construction of DAC

DAC curves are to be constructed from the drilled holes in the parent material of the reference blocks, see Table 6-1 and Fig. 6-16.

A maximum response shall then be obtained from the holes in the weld fusion zone and if necessary the gain setting shall be adjusted such that this response reach DAC, see Fig. 6-16. This shall be the primary gain to be used when locating indications on the fusion boundary in those cases where the ultrasonic beam is passing through the parent metal only.

An other set of DAC curves shall be constructed, as shown in Fig. 6-16, in order to establish sensitivity levels for instance where the ultrasound is traversing the weld material, when scanning the fusion face.

These sensitivity levels shall be verified against the holes drilled in the base material. Any variations must be noted so that echoes reflected from indications within the weld zone can be evaluated for amplitude response.

It must be verified on reference blocks with welds produced in accordance with the actual WPS, if a $1.5 \times S$ (full skip scanning) is possible to obtain using shear wave angle probes. Note that angle compression wave probes can only be used at $\frac{1}{2} S$ scanning.

The eroded notches on the surface of the reference block, see Fig. 6-17, for creep wave probes is to be used for sensitivity setting. It is recommended to adjust the echo response from the 1.0 mm notch to 75% of FSH.

6.7.11 Transfer correction

Due to the fact that compression wave angle probes can only be used on $\frac{1}{2}$ skip, transfer correction, as described

in 6.6.6, is not possible to perform. The reference blocks must, for this reason, have a surface finish similar to the production material.

6.7.12 Testing of parent metal and welds

See 6.6.7.

6.8 Evaluation of imperfections in weld connections

Imperfections, from which the reflected echo response is greater than 33% (-10 dB) of the reference level shall be investigated to the extent that the operator can determine the shape, identity and location of all such imperfections and evaluate them in terms of the acceptance criteria.

The length of the imperfection shall be determined by measuring the distance along the length over which the echo amplitude exceeds the evaluation level. Final evaluation against the acceptance criteria shall be based on the echo amplitude and length measured with the probe angle giving the maximum response.

All defects exceeding the acceptance criteria shall be reported unless more stringent requirements to reporting are agreed.

6.9 Acceptance Criteria, Weld Connections

Whenever acceptance criteria are defined in the Rules, approved drawings, IACS Recommendations or other agreed product standards, these criteria are mandatory.

Unless otherwise agreed, all indications in the test volume (defined in 6.6.1) shall follow the acceptance criteria for the weld connection. However, indications found in the parent metal and heat affected zone (as included in the test volume defined in 6.6.1), and judged “beyond reasonable doubt” to be laminar imperfections originating from the plate rolling process, may follow the acceptance criteria for the plate (6.11.7).

If no acceptance criteria are defined, acceptance criteria as specified below may be applied for welds in C, C-Mn steels, alloy steels, aluminium, austenitic stainless steel and ferritic-austenitic stainless steel.

Table 6-3 Acceptance criteria for ultrasonic testing	
<i>ECHO HEIGHT</i>	<i>ACCEPTANCE CRITERIA FOR ULTRASONIC TESTING1)</i>
Equal or greater than 100% of DAC Curve	maximum length t/2 or 25mm whichever is the less
Greater than 50% of DAC curve but less than 100% of DAC curve	maximum length t or 50mm whichever is the less
<p>Indications above the evaluation level (33% of DAC) and evaluated to be two dimensional imperfection, such like cracks, lack of fusion and lack of penetration, are unacceptable regardless of echo height;</p> <p>Characterisation of indications are based on echo amplitude – (stage 1 and 2) and directional reflectivity criteria (stage 3) given in ISO 23279:</p> <p><i>Low amplitudes (stage 1)</i> An indication having echo amplitude lower than the evaluation level is not significant and shall not be characterised.</p> <p><i>High amplitude (stage 2)</i> An indication having echo amplitude that is at least equal to the reference level plus 6 dB is a planar defect.</p> <p><i>Directional reflectivity criteria (stage 3)</i> By comparing the maximum echo amplitude from an indication using two probe angles having different refraction angles of more than 10° the difference shall be more than 9 dB. When comparing the amplitude from a shear wave angle probe and a compression wave normal probe, the difference shall be more than 15 dB.</p>	

DAC is based on a Ø 3 mm drilled hole.

The above levels are considered equal to acceptance level 2 and 3 of EN 1712 and correspond to quality levels B and C of EN-ISO 5718, ref. correlation given in EN –ISO 11666 and EN-ISO 17635.

In addition the following applies: All indications from which the reflected echo amplitude exceeds the evaluation level shall be characterized and all that are characterized as planar (e.g. cracks, lack of fusion and incomplete penetration) shall be rejected, ref. EN-ISO 11666.

6.10 Reporting, weld connections

In addition to the items listed under item 1.11 Final report, the following have to be included in the ultrasonic testing report:

- probes, type and frequency
- identification of reference blocks used
- couplant medium

- reporting level, if different from acceptance level
- calibration range
- scanning technique, half skip or full skip scanning.
- surface compensation/transfer correction
- defect type (At least defined as Spherical, Volume or Planar)
- example of report sheet with defect notes, see Fig. 6-19.

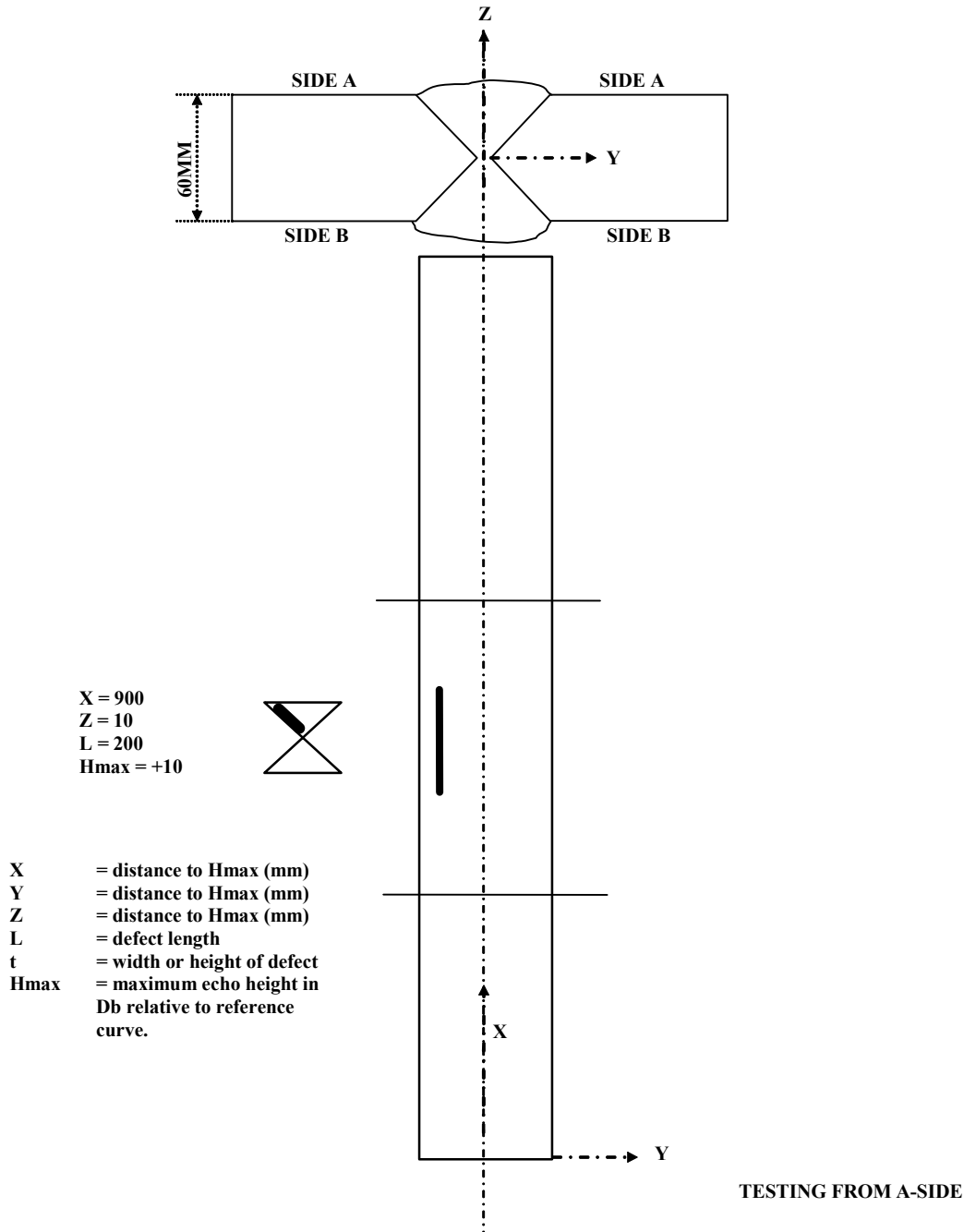

Figure 6-19
Example of sketch with notes

6.11 Ultrasonic testing of rolled steel plates

This chapter covers manual testing of rolled plates in carbon and alloy steel with thickness ≥ 6.0 mm for the detection of imperfections which are oriented parallel with the rolled surface.

The intention of the ultrasonic testing is to ensure that the steel plates are free of gross discontinuities such as planar inclusions or laminations.

6.11.1 Personnel qualifications and requirements for equipment

6.11.1.1 Personnel

Personnel performing testing of rolled steel plates shall be qualified and certified to UT level 1, as a minimum, in accordance with EN 473, ISO 9712 or an equivalent recognised standard or certification schemes e.g. PCN or NORDTEST. Other recognized national certification schemes may be considered.

6.11.1.2 Ultrasonic apparatus

The apparatus shall:

- be applicable for the pulse-echo technique and for the double-probe technique
- cover a minimum frequency range from 1 to 6 MHz
- have a calibrated gain regulator with minimum 2 dB pr. step over a range of minimum 60 dB
- be equipped with a flat screen accessible from the front for direct plotting of Distance Amplitude Curves (DAC) or be equipped with automatic DAC- display presentation
- have the opportunity for mounting distance grain size (DGS) -scales on the screen
- be able to clearly distinguish echoes with amplitudes of 5% of full screen height.

6.11.2 Probes

The probes shall be straight beam transducers (normal probes) single- or twin crystal.

Twin crystal probes shall be used when examination is performed on steel plates with nominal thickness $T < 60$ mm.

Single or twin crystal probes can be used when testing is performed on steel plates with nominal thickness $T \geq 60$ mm.

The single crystal probes shall have a dead zone as small as possible, e.g. 15% of the plate thickness or 15 mm whichever is the smaller. The focusing zone of the twin crystal probes shall be adapted to the thickness of the plate to be examined.

Selected probes shall have a nominal frequency in the range of 2 MHz to 5 MHz and dimensions $\varnothing 10$ mm to $\varnothing 25$ mm.

6.11.3 Coupling medium and surface conditions

The coupling medium shall ensure an adequate contact between the probe and the surface of the steel plate to be tested. Water is normally used but other coupling media, e.g. oil or paste, may be used.

The surface condition shall permit at least two successive back-wall echoes to be distinguished when the probe is placed on any area free from internal imperfections.

6.11.4 Calibration

6.11.4.1 Calibration of range scale

The calibration of range scale is to be carried out using an IIW calibration block, a K2 calibration block or on a defect free area of the material to be examined.

The range scale is to be selected such that there are always at least 2 back-wall echoes (reflections) on the screen.

6.11.4.2 Calibration of sensitivity

The calibration of sensitivity is based on echoes reflected from flat bottom holes in reference blocks of carbon steel. Characteristics curves corresponding to flat bottom holes with various diameter can be supplied by the manufacturer of the probes. The curves are either presented on a DGS diagram or on DGS - scales "attachment scales" to be mounted on the screen of the ultrasonic apparatus.

The DGS - scales, which are most commonly used, are developed from the DGS diagrams. Differently sized reflectors (flat bottom holes "FBH") can be correlated to the evaluating curves. The FBH. reflectors are used as reference sizes for evaluating echo amplitudes.

By using a DGS - scale it is possible to evaluate echo amplitudes reflected from imperfections quickly and directly. The evaluation is done by measuring the dB distance from an evaluation curve.

6.11.5 Evaluation of imperfections

Only imperfections from which the reflected echo amplitude is greater than that of the characteristic curve of a $\varnothing 11$ mm FBH. shall be taken into account.

The area of the imperfections shall be determined using the 6 dB-drop technique whenever complete loss of back wall echo is obtained, see Fig. 6-20.

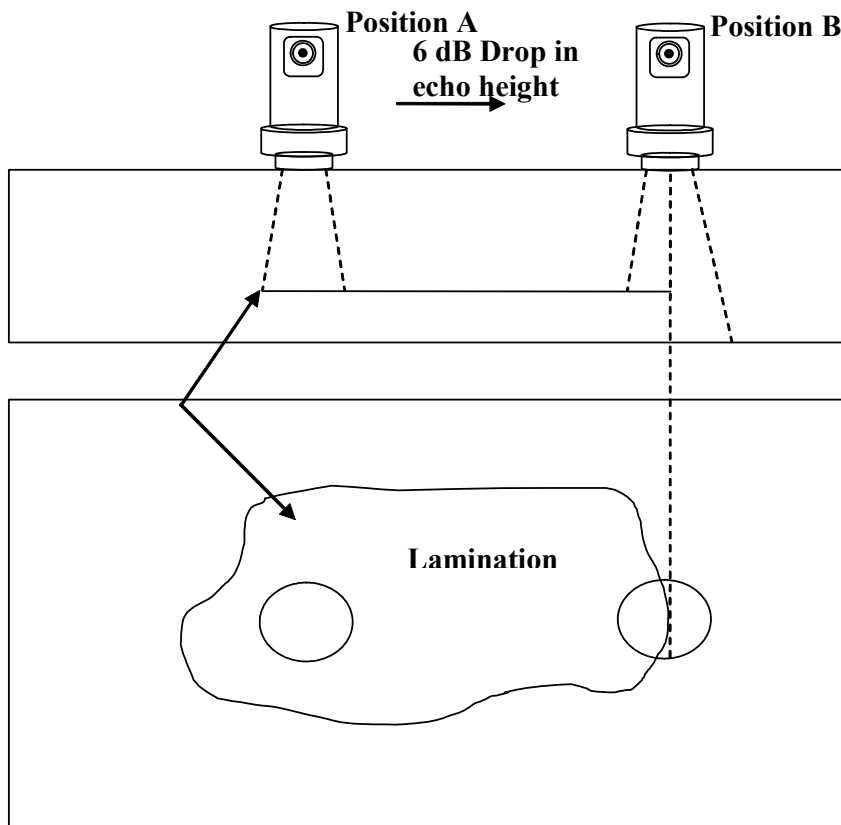

Figure 6-20
Half value method

Using single crystal probes the imperfections giving echoes above the characteristic curve for the Ø11 mm FBH. are to be counted and evaluated against the acceptance criteria.

Two nearby imperfections shall be considered as one, the area being equal to the sum of the two, if the distance between them is less than or equal to the length of the smaller of the two.

6.11.6 Scanning

Scanning comprises in general continuous examination along the lines of a grid made of a 200 mm square parallel to the edges of the plate, or along parallel or oscillating lines distributed uniformly over the surface, giving the same degree of control.

Scanning of plate edges comprises a full examination of zone in accordance with Table 6-5 over the four edges of the plate.

Table 6-4 Zone width for steel plate edges	
<i>Thickness of plate, T, (mm)</i>	<i>Zone width (mm)</i>
10 ≤ T < 50	50
50 ≤ T < 100	75
100 ≤ T	100

6.11.7 Acceptance criteria

Whenever acceptance criteria are defined in the Rules, approved drawings, IACS Recommendations or other agreed product standards, these criteria are mandatory. If no acceptance criteria are specified the quality class S1 – E2 of EN 10160, see Tables 6-6, 6-7 and 6-8, applies.

Table 6-5 Acceptance criteria for testing with twin crystal probes for steel plates $T < 60$ mm

Class S1	Unacceptable		Acceptable clusters of discontinuities	
	Individual discontinuity (mm^2)		Area*considered (mm^2)	Maximum density not greater than 15, in the most populated $1\text{ m} \times 1\text{ m}$ square
	A > 1000		$100 < A \leq 1000$	

* Area of each discontinuity in the cluster in question

Table 6-6 Acceptance criteria for testing with normal (single crystal) probes

Class S1	Unacceptable		Acceptable clusters of discontinuities	
	Individual discontinuity (mm^2)		Dimensions* (number considered) (mm^2)	Maximum number not greater than 15, in the most populated $1\text{ m} \times 1\text{ m}$ square
	A > 1000		$100 < A \leq 1000$	

* Dimensions of each discontinuity in the cluster in question

Table 6-7 Acceptance criteria for edge zone examination

Class	Permissible individual Discontinuity size			
	Maximum dimension L_{\max}	Maximum area A_{\max}	Minimum discontinuity dimension considered L_{\min}	Permissible number of discontinuities smaller than the maximum area A_{\max} and longer than L_{\min} per 1m length
	(mm)	(mm^2)	(mm)	
E2	40	500	20	4

6.11.8 Reporting, rolled steel plates

In addition to the items listed under 1.11 Final report, the following have to be included in the ultrasonic testing report:

- probes, type and frequency
- identification of reference blocks used
- couplant medium
- reporting level, if different from acceptance level.

6.12 Ultrasonic testing of castings

This part covers manual testing of castings, carbon, low-alloy and martensitic stainless steel using the flat bottom hole calibration technique.

The intention of the testing is to reveal unacceptable internal imperfections.

Testing is to be carried out after final heat treatment when the casting surface has been brought to a condition suitable for UT.

As an alternative to the flat bottom hole calibration technique the DGS technique may, upon agreement with the Society, be accepted. The DGS technique is described in chapter 6.13 “Ultrasonic testing of Forgings”.

The back wall echo obtained on parallel sections should be used to monitor variations in probe coupling and material attenuation. Any reduction in the amplitude of the back wall echo without evidence of intervening defects should be corrected. Attenuation in excess of 30 dB/m could be indicative of an unsatisfactory annealing heat treatment.

6.12.1 Personnel qualifications and requirements for equipment

6.12.1.1 Personnel

Personnel performing testing of castings shall be qualified and certified to UT level 2 or 3 in accordance with EN 473, ISO 9712 or an equivalent recognised standard or certification scheme e.g. PCN or NORDTEST. Other recognised national certification schemes may be considered.

In addition, the personnel shall be familiar and trained with use of flat bottom hole calibration technique.

6.12.1.2 Ultrasonic Apparatus

The apparatus shall:

- be applicable for the pulse-echo technique and for the double-probe technique
- cover a minimum frequency range from 1 to 6 MHz
- have a calibrated gain regulator with minimum 2 dB pr. step over a range of minimum 60 dB
- be equipped with a flat screen accessible from the front for direct plotting of 'Distance Amplitude Curves' (DAC) or be equipped with automatic DAC- display presentation
- be able to clearly distinguish echoes with amplitudes of 5% of full screen height.

6.12.1.3 Probes

The probes shall be straight beam transducers (normal probes) single- or twin crystal.

Twin crystal probes shall be used when testing is performed on castings with nominal thickness $T \leq 25$ mm.

Selected probes shall have dimensions $\varnothing 10$ mm to $\varnothing 30$ mm. The background noise shall not exceed 25% of DAC.

Supplementary:

Angle beam probes shall be used only when agreed upon between the contracting parties or required by the Society. Typical applications are castings that cannot be effectively tested using a straight beam probe as a result of casting design or possible discontinuity orientation.

It is recommended to use probes producing angle beam in steel in the range 35° to 75° inclusive, measured to the perpendicular of the entire surface of the casting being tested.

As a minimum a 45° probe is to be used.

6.12.2 Surface preparation and coupling medium

All surfaces to be examined shall be free of any substance which may impede the free movement of the probe or hinder the transmission of ultrasound to the material. Machined surfaces should be preferred for the final examination.

As coupling medium oil, grease or cellulose gum will be used. The coupling medium used for calibration shall also be used for examination.

6.12.3 Calibration of range scale

The same equipment shall be used during calibration and examination, e.g. apparatus, probes, cables and coupling medium.

The temperature of the test object and the calibration-/reference blocks shall be within $\pm 14^\circ\text{C}$.

Calibration of range scale with normal probes is to be performed using K1/K2 calibration blocks or the reference block for calibration of amplification.

The range scale for normal probes is to be selected such that there are always at least 2 back-wall echoes (reflections) on the screen.

The range for the angle probe must cover min. $1 \times S$ (Skip distance) if scanning is accessible only from one surface. If scanning is possible from two surfaces (inside/outside) $0.5 \times S$ is sufficient.

6.12.4 Reference blocks

Basis for the calibration is a set of test blocks containing flat bottom holes. The reference blocks shall have the same acoustic properties/material grade as the material to be examined.

In addition the blocks shall be stamped with the reference charge/heat number for traceability to the actual material certificate, and also be given the same heat treatment as the test object.

The following blocks are to be used:

6.12.4.1 Block no 1

Ultrasonic Standard Reference Blocks as specified in ASTM SA609/SA609M 4.3.3, Fig.1 and Table 1.

The blocks are used for calibration of the normal probes. The dimension of the blocks are depending of the thickness of the test object. The basic set shall consist of those blocks listed in table 1. When section thicknesses over 380 mm are to be tested, an additional block of the maximum test thickness shall be made to supplement the basic set. The drilled hole acting as reference reflector is a flat bottom hole with diameter 6.4 mm.

6.12.4.2 Block no. 2

Ultrasonic Standard Reference Block for calibration of twin crystal (transmitter/receiver T/R) probes. The block shall be machined and contain 2.4 mm drilled holes in various depths as shown in ASTM SA609/SA609M 4.3.3, Fig. 2. The block is to be used for calibration of the T/R Probe for examination of objects with thickness ≤ 25 mm.

6.12.4.3 Block no 3

Basic Calibration block for angle Beam Examination is shown in ASTM SA609/SA609M Fig. S1.1.

6.12.5 Calibration of amplification

6.12.5.1 Straight beam probes

Calibration of the amplification shall include the whole of the ultrasonic system, this includes the ultrasonic apparatus, probes, cables and coupling medium.

The blocks that encompasses the metal thickness to be inspected are to be used for calibration.

Adjust the instrument controls to position the first back reflection for the thickness to be tested at least one half of the distance across the cathode ray tube.

Using the set of reference blocks spanning the thickness of the casting being inspected, mark the flat bottom hole indication height for each of the applicable blocks on the cathode ray tube shield. Draw a curve through these marks on the screen or on a suitable graph paper. The maximum signal amplitude for the test blocks used shall peak at approximately 80% of the screen height above the sweep by use of the attenuator. This curve shall be referred to as 100% distance amplitude correction (DAC) curve.

The casting testing surface will normally be rougher than that of the test blocks; consequently, employ a transfer mechanism to provide approximate compensation. In order to accomplish this, first select a region of the casting that has parallel walls and a surface condition representative of the rest of the casting as a transfer point. Next select the test block whose thickness most closely matches the thickness of the test object.

Place the search unit on the casting at the transfer point and adjust the instrument gain until the back reflection amplitude through the casting matches that through the test block.

Using this transfer technique the variation in attenuation/surface condition between the calibration block and test object can be found and taken into consideration.

Do not change those instrument controls and the test frequency set during calibration, except the attenuator, or calibrated gain control, during acceptance examination of a given thickness of the casting. Make a periodic calibration during the inspection by checking the amplitude of response from the 6.4 mm (2.4 mm for T/R probes) diameter flat-bottom hole in the test block utilized for the transfer.

The attenuator or calibrated gain control may be used to change the signal amplitude during examination to permit small amplitude signals to be more readily detected. Signal evaluation is made by returning the attenuator or calibrated gain control to its original setting.

During examination of areas of casting having parallel walls recheck areas showing 75% or greater loss of back reflection to determine whether loss of back reflection is due to poor contact, insufficient couplant, mis-oriented discontinuity, etc. If the reason for loss of back reflection is not evident, consider the area questionable and investigate further.

6.12.5.2 Angle Probe

The angle probe is to be calibrated using a set of calibration blocks with side-drilled holes at $1/4 t$, $1/2 t$ and $3/4 t$ (where t = thickness of the block).

The hole diameter is depending on the thickness of the casting being tested.

Use the reflection (amplitude) from the side drilled holes to establish the applicable DAC as described in 6.6.4.

The basic calibration blocks shall be made of material that is acoustically similar to the casting being examined.

A machined calibration block is to be used for machined surfaces.

6.12.6 Scanning

All surfaces specified for ultrasonic testing shall be completely inspected from both sides, whenever both sides are accessible. Where scanning is restricted to one side only scanning is to be performed using a twin crystal probe for the near surface scans (25 mm below surface) and a single probe for the remaining volume.

When practical radial and axial scanning are to be performed.

The scanning rate shall not exceed 100 mm/s.

The operators shall ensure complete coverage of all areas specified for testing by carrying out systematically overlapping of scans. Minimum scanning speed shall not exceed 100 mm/s and the each pass of the search unit shall overlap a minimum of 10% of the active transducer (piezoelectric element).

6.12.7 Reporting, casting

In addition to the items listed under 1.11 Final report, the following have to be included in the ultrasonic testing report:

All indications from which the reflected echo response are greater than 100% of DAC is to be reported.

Areas showing 75% or greater loss of back reflection are to be reported if, upon further investigation, the reduction of reflection is evaluated to be caused by discontinuities.

6.12.8 Acceptance criteria

Whenever acceptance criteria are defined in the Rules, approved drawings, IACS Recommendations or other agreed product standards, these criteria are mandatory. For hull castings, IACS Recommendation No. 69 is regarded as an example of an acceptable standard.

6.13 Ultrasonic testing of forgings

This chapter covers manual testing of forgings of carbon or low-alloy steel using the straight- and angle beam technique. The straight beam technique utilised is the DGS (Distance Gain Size) method.

The intention of the testing is to reveal unacceptable internal discontinuities.

Final testing is to be carried out after heat treatment when the forging surface has been brought to a condition suitable for UT.

6.13.1 Personnel qualifications and requirement for equipment

6.13.1.1 Personnel

Personnel performing testing of forgings shall be qualified and certified to UT level 2 or 3 in accordance with EN 473, ISO 9712 or an equivalent recognised standard or certification scheme e.g. PCN or NORDTEST. Other recognized national certification schemes may be considered.

In addition, the personnel shall be familiar and trained with use of the DGS method.

6.13.1.2 Ultrasonic Apparatus

The apparatus shall:

- be applicable for the pulse-echo technique and for the double-probe technique
- cover a minimum frequency range from 1 to 6 MHz
- have a calibrated gain regulator with minimum 2 dB pr. step over a range of minimum 60 dB
- be equipped with a flat screen accessible from the front for direct plotting of “Distance Amplitude Curves” (DAC) or be equipped with automatic DAC- display presentation
- have the opportunity for mounting DGS-scales on the screen
- be able to clearly distinguish echoes with amplitudes of 5% of full screen height.

6.13.1.3 Probes

Straight beam (normal) probes with frequency 2-4 MHz and dimension \varnothing 10-30 mm are to be used. Angle beam probe is to be used as supplementary testing on rings, hollow and cylindrical sections.

It is recommended to use probes producing angle beam in steel in the range 35° to 75° inclusive, measured to the perpendicular of the entire surface of the casting being tested. As a minimum a 45° probe is to be used.

6.13.2 Surface preparation and coupling medium

All surfaces to be tested shall be free of any substance which may impede the free movement of the probe or hinder the transmission of ultrasound to the material. Machined surfaces should be preferred for the final examination.

Unless otherwise specified the forgings shall be machined to provide cylindrical surfaces for radial testing in the cases of round forgings; the ends of the forgings shall be machined perpendicular to the axis of the forging for the axial testing. Faces of disk and rectangular forgings shall be machined flat and parallel to one another.

As coupling medium oil, grease or cellulose gum will be used. The coupling medium used for calibration shall also be used for examination.

6.13.3 Calibration of range scale

The same equipment shall be used during calibration and examination, e.g. apparatus, probes, cables and coupling medium.

The range scale for normal probes is to be selected such that there always are at least 2 back-wall echoes (reflections) on the screen.

The range for the angle probe must cover min. $1 \times S$ (Skip distance) if scanning is accessible only from one surface. If scanning is possible from two surfaces (inside/outside) $0.5 \times S$ is sufficient.

6.13.4 Calibration of amplification

6.13.4.1 Probes

6.13.4.1.1 Normal probes

DGS scales, matched to the ultrasonic test unit and probes, are to be used for straight-beam testing. The DGS scale range must be selected to include the full thickness cross-section of the forging to be tested.

Insert the DGS scale on the ultrasonic apparatus cathode-ray tube (CRT) screen ensuring the DGS scale baseline coincides with the sweep line of the CRT screen. Place the probe on the forging and adjust the first backwall echo to appear clearly on the CRT screen at the value corresponding to the thickness of the forging. Adjust the gain so the forging back wall echo matches the height of the DGS reference slope within ± 1 dB. Once adjusted, increase the gain by the dB value shown on the DGS scale for the reference slope.

The instrument is now calibrated and can be used for all solid-cylinder forgings (non-drilled) and plane backwall forgings. If the ultrasonic test unit is equipped with digital DGS, Calibration Interface Program this program, allowing creating specific DGS scales electronically, might be used.

Testing cylindrical hollow forgings the hole of the specimens causes sound scatter. In these cases a correction depending of the specimen thickness and the hole diameter is required.

Determine the correction value in dB from the Nomogram shown in ASTM SA-388/SA-388M, Fig. X4.2 Nomogram.

Proceed as described above. Using the gain "Gain-dB" control reduce the flaw detector by the correction value determined using the Nomogram.

The apparatus is then calibrated for testing cylindrical bored or hollow forgings.

6.13.4.1.2 Angle Probe

Rings and hollow sections with an outside to inside diameter (OD/ID) less than 2.0 to 1.0 should be tested using angle probes, at least 45° probe as a supplement to the normal probe. Forgings which cannot be tested axially using normal probes, are also to be tested with the use of angle probes, min. 45° probe.

Calibrate the apparatus for the angle beam testing to obtain an indication amplitude of approximately 75% of FSH from a rectangular or 60° V-notch on inside diameter in the axial direction and parallel to the axis of the forgings to be tested.

A separate calibration standard (block) may be used, however, it shall have the same configuration, nominal composition, heat treatment and thickness as the forgings it represents.

Where a group of identical forgings is made, one of the forgings may be used as the separate calibration standard.

Cut the ID depth notch to 3% maximum of the thickness or 6 mm, whichever is smaller, and its length to approximately 25 mm. At the same instrument setting, obtain a reflection from a similar OD notch. Draw a line through the peaks of the first reflections obtained from the ID and OD notches. This shall be the amplitude reference line ("DAC").

When practical utilise the ID notch when scanning from the OD surface and the OD notch when scanning from the ID surface. Curve wedges or probe-shoes may be used when necessary for a proper contact between probe and testing surface.

6.13.5 Scanning

6.13.5.1 Normal probes

All surfaces specified for ultrasonic testing shall be completely inspected from both sides, whenever both sides are accessible. Where access is restricted to one side only scanning is to be performed using a twin crystal probe for the near surface scans (25 mm below surface) plus a single probe for the remaining volume.

When practical both radial and axial scanning are to be performed.

On larger diameter rudder stocks and especially axial scanning, the Pulse Repetition Frequency (PRF) must be limited to max. 150 Hz to avoid false signals due to interference on larger dimensions.

The scanning rate shall not exceed 100 mm/s.

The operators shall ensure complete coverage of all areas specified for testing by carrying out systematically overlapping of scans. In general the testing is to be carried out prior to drilling holes, tapers, grooves, or machining sections to contour.

6.13.5.2 Angle probes

Rings and hollow sections as specified in item 6.13.4.1.2 are to be tested using angle probe. The testing is to be performed by scanning over the entire surface area circumferentially in both the clockwise and counter clockwise direction from the OD surface.

Forgings which cannot be tested axially by normal probes are to be tested in both axial directions with an angle-beam probe. For axial scanning the notches as specified in item 6.13.4.1.2 are to be used for calibration. These notches, placed on the ID and OD surface, shall be perpendicular to the axis of the forging and have the same dimensions as the axial notch.

6.13.6 Sizing of imperfections

In general, the area containing imperfections, is to be sized (area and length) using the 6 dB drop technique.

The area refers to the surface area on the forgings over which a continuous indication exceeds the acceptance criteria. This area will be approximately equal to the area of the real defect provided the defect size is larger than the 6 dB beam profile of the probe.

However, if the real imperfection size is smaller than the 6 dB beam profile, the 6 dB drop technique is not suited for sizing. The area measured on the surface will, in such cases, be measured too large and not represent the real indication size.

A guide to classify if the revealed indications are greater or smaller than the 6 dB drop profile is given in EN 10228-3, part 13.

If the size of the indication is evaluated to be smaller than the 6 dB drop profile at the depth of discontinuity a graphic plot, that incorporates a consideration of beam spread, should be used for realistic size estimation.

In certain forgings, because of very long metal path distances or curvature of the scanning surfaces, the surface area over which a given discontinuity is detected may be considerably larger or smaller than the actual size of the discontinuity; in such cases criteria that incorporate a consideration of beam angles or beam spread must be used for realistic size evaluation.

This might include calibration blocks identical with the forgings to be tested. In cases of dispute flat bottom holes or notches, drilled or machined in the calibration blocks, can act as reflectors to verify the correct defect size.

6.13.7 Reporting, forgings

In addition to the items listed under 1.11, Final report, the following have to be included in the ultrasonic testing report:

With normal probes:

- All indication from which the reflected echo response exceeds the specified DGS acceptance criteria are to be reported.
- An indication that is continuous on the same plane and found over an area larger than twice the probe diameter is to be reported regardless of echo amplitude.
- Areas showing 20% or greater loss of back reflection is to be reported if, upon further investigation, the reduction of reflection is evaluated to be caused by discontinuities.

When using angle probes:

- Record discontinuities indications equal to or exceeding 50% of the indication from the reference line.

The above reportable indications do not by themselves mean a rejectable condition, unless specified in the acceptance criteria.

6.13.8 Acceptance Criteria

Whenever acceptance criteria are defined in the Rules, approved drawings, IACS Recommendations or other agreed product standards, these criteria are mandatory. For hull and machinery steel forgings, IACS Recommendation No.68 is regarded as an example of an acceptable standard.

Any reflections caused by discontinuities, exceeding 20% of full screen height, is not acceptable.

7. Visual Inspection

7.1 Scope

This part specifies visual testing of fusion welds in metallic materials.

The testing is to be performed in the as-welded condition including testing of repaired welds.

7.2 Information required prior to testing

See general information under Sec.1 Introduction .

7.3 Requirements for personnel and equipment

7.3.1 Personnel qualifications

Personnel performing visual inspection shall be qualified and certified to an appropriate level in accordance with EN 473, ISO 9712 or other equivalent recognised standard or national certification schemes.

7.3.2 Equipment

The following equipment may be needed:

- for visual testing of welds with limited accessibility; mirrors, endoscopes, boroscopes, fibre optics or TV-cameras
- magnifying lens
- radius gauge
- various set of weld gauges for measuring fillet welds, reinforcement, undercuts, misalignment etc.
- light source.

7.4 Testing conditions

The luminance at the surface, shall be minimum 500 lx.

If required to obtain a good contrast and relief effect between imperfections and background, an additional light source should be used.

For performance of direct inspection, the access shall be sufficient to place the eye within 600 mm of the surface to be inspected and at an angle not less than approximately 30°.

7.5 Testing volume

If not otherwise agreed all weld connections in question should be 100% visually inspected.

The testing volume shall as a minimum cover the zone which includes welds and parent metal for at least 20 mm on each side of the weld.

In case of doubt, visual testing should be supplemented by other non-destructive testing methods for surface inspections.

7.6 Preparation of surfaces

The weld surface shall be free of weld spatter, slag, scale, oil, grease, heavy and loose paint or other surface irregularities which might avoid imperfections from being obscured.

It can be necessary to improve the surface conditions e.g. by abrasive paper or local grinding to permit accurate interpretation of indications.

7.7 Evaluation of indications

The weld shall be visually tested to check that the following meets the requirements of the agreed acceptance criteria:

- the profile of the weld face and the height of any excess weld metal
- the surface of the weld is regular and present an even and satisfactory visual appearance
- the distance between the last layer and the parent metal or the position of runs has been carried out as required as described by the WPS
- the weld merge smoothly into the parent metal.
- the fillet welds have correct throat thickness and geometry
- undercuts, porosity or other surface imperfections to be within the maximum limit
- in case of butt welds it shall be checked that the weld preparation has been completely filled
- in case of single sided butt welds, the penetration, root concavity and any burn-through or shrinkage grooves are within the specified limits.

Weld zones in stainless steels, Nickel and Titanium alloys shall be visually inspected and fulfil the criteria for oxidation levels (surface colour).

In addition:

- any attachments temporarily welded to the object shall be removed. The area where the attachment was fixed shall be checked to ensure freedom of unacceptable imperfections
- all sharp corners adjacent to the weld are to be rounded. Preparation of edges/structural shapes to be prepared to an acceptable surface finish.

7.8 Visual testing of repaired welds

When welds fail to comply wholly or in part with the acceptance criteria and repair is necessary, the following actions shall be made:

- if removal of metal exceeds 7% of the wall thickness or 3 mm, whichever is less, repair welding is required according to an approved procedure
- if the weld is partly removed it shall be checked that the excavation is sufficiently deep and long to remove all imperfections. It shall also be ensured that there is a gradual taper from the base of the cut to the surface of the weld metal at the ends and sides of the cut. The width and profile of the cut must be prepared such that there is adequate access for re-welding
- it shall be checked that, when a cut has been made through a faulty weld and there has been no serious loss of material, or when a section of materials containing a faulty weld has been removed and a new section is to be inserted, the shape and dimensions of the weld preparation meet the requirements
- in case where part of a weld is gouged out the excavated area shall be ground and either magnetic particle testing or penetrant testing should be carried out prior to re-welding in order to ensure that the imperfection is removed.

7.9 Acceptance criteria

Whenever acceptance criteria are defined in the Rules, approved drawings, IACS Recommendations or other agreed product standards, these criteria are mandatory. If no acceptance criteria are specified Quality Class C – Intermediate of EN-ISO-5817 applies. For highly stressed areas more stringent requirements, such as Quality Level B, may be applied.

Appendix A Guidelines Regarding Ultrasonic Testing of Thermo Mechanically Controlled, Processed (TMCP) Materials and Determination of the Root Area in Single Sided Welds

A.1 TMCP

A.1.1 Introduction

Characteristics of ultrasonic waves in anisotropic steels and difference due to propagation direction of ultrasonic waves.

In ultrasonic angle beam examination, no variation arises in refraction angle or echo height with the propagation direction (longitudinal- or transverse to rolling direction) for isotropic steels, but the influence of the propagation direction of ultrasonic waves might be significant for anisotropic steels such as TM/TMCP materials.

The actual refraction angle varies with the propagation direction; the actual refraction angle can be larger than the nominal angle in the rolling direction (longitudinal L-direction), while it can be smaller in the transverse direction (T-direction). The echo height obtained using nominal 45° probe is normally nearly equal in the L-direction and in the T-direction, where the echo height with the nominal 60° and 70° probe might be much lower in the L-direction, and the position of its maximum amplitude is unclear.

Transmitted pulse amplitude and actual refraction angle of various types of anisotropic steels can be determined by the V-path method, shown in Fig. A-1.

A.1.2 Measurement of difference in angle of refraction and echo height/amplitude

The measurement of the difference in angle of refraction shall be carried out as follows:

Use the same type of probe as shall be used for the flaw examination (60° and 70°) and oppose these to each other in the direction of L (main rolling direction) or T (perpendicular to the rolling direction) as shown in Fig. A-1. Adjust the position of probe so that maximum transmission pulse strength (echo height) is obtained by the arrangement of V scanning/path. The actual probe angle refraction α_L or α_T can be calculated using the formula for skip-distance S between the points of incidence at the position where the largest transmission pulse strength has been obtained:

$$S = 2t \times \tan \alpha.$$

$$\left(\tan^{-1} \alpha = \frac{S}{2t} \right)$$

The difference between the measured/calculated values of α_L and α_T shall be considered and compared to the nominal probe angle.

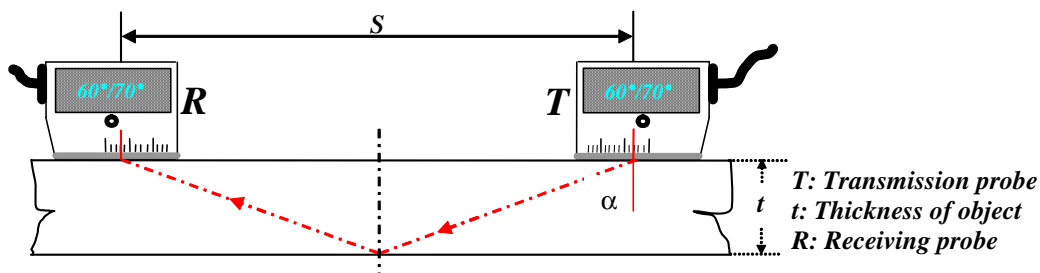

**Figure A-1
Through Transmission Technique**

Also the echo height (amplitude) obtained when the probes are positioned respectively in the rolling direction and perpendicular to the rolling direction must be considered.

A.1.3 Verification and adjustment (TM/TMCP)

The acoustic anisotropy shall be measured in accordance with Sec.2. If the result of the measurement confirms that the material is anisotropic the following shall be carried out: When the measured angle refraction deviates more than +/- 2°, compared to the nominal probe angle, or the echo height varies more than +/-2dB the result

of this measurement for both angle deviation and the attenuation/damping of the echo amplitude shall be adjusted and recorded before testing.

A.1.4 Reference block for TM/TMCP materials

When ultrasonic testing is performed on such materials, reference blocks shall be made out of the same material grades (and traceable to Heat No.) used in the production. The reference block shall have a dimension of min. $2 \times$ full skip for 70° angle probe in both longitudinal rolling direction and perpendicular to the rolling direction, see Fig. A-2 and A-3. A side drill hole (SDH) of diameter 3.0 mm shall be made in a depth of $\frac{1}{2}$ or $\frac{3}{4}$ of the thickness of the block in both directions. Due to deviation in attenuation and refraction angle for these materials, the result of this measurement must be adjusted before examination.

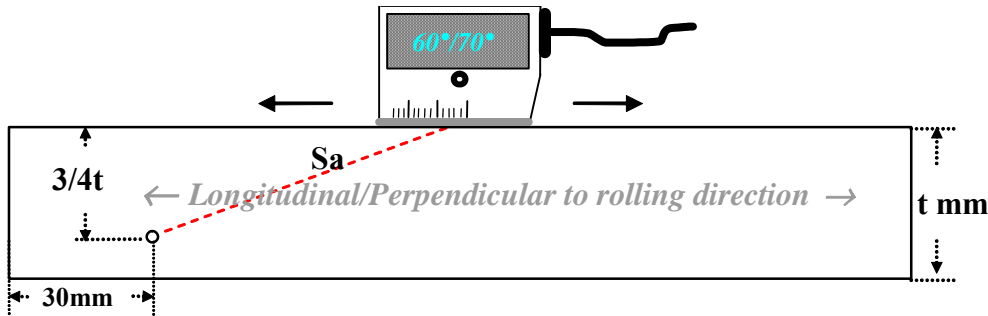

Figure A-2
Cross section

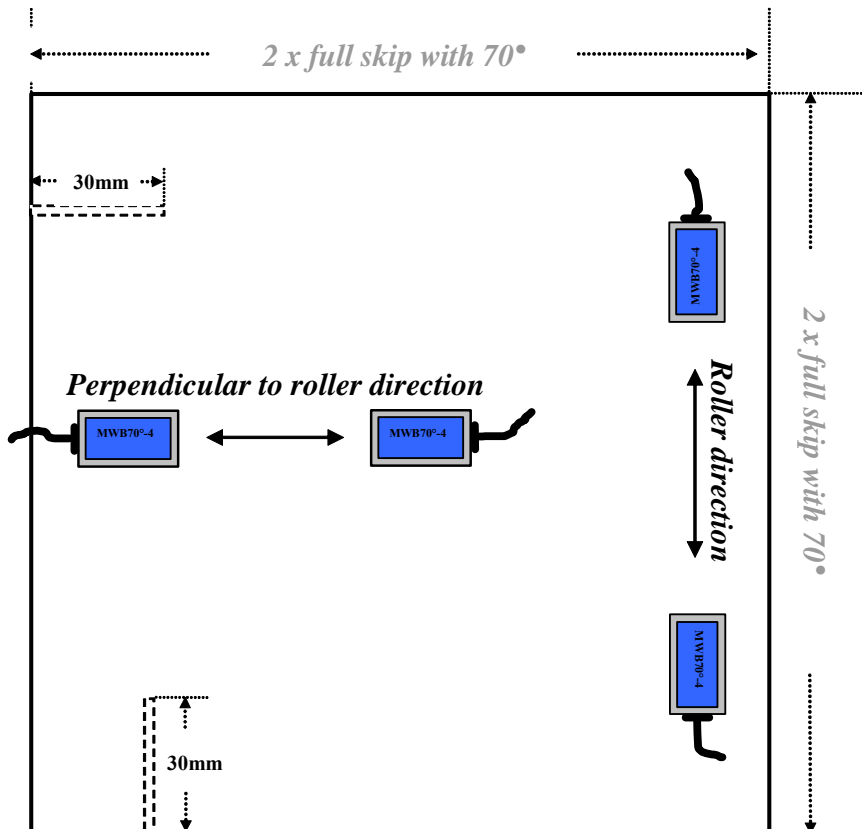

Figure A-3
Top view

A.1.5 Conclusion for field verification

When ultrasonic testing is performed on TM/TMCP material without having reference block of the actual material, angle deviation and material attenuation must be adjusted before start of testing. Projects with use of large amount of such material reference block must be made.

A.2 Ultrasonic testing and determination of single welded root areas

A.2.1

The configuration of the root area shall be judged by measuring the horizontal distances (a) as shown in the figures below:

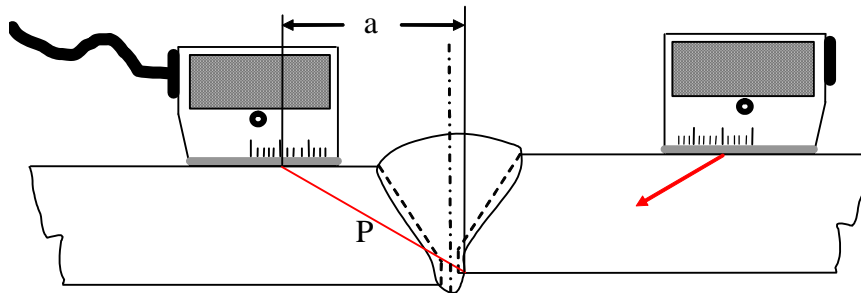

Figure A-4
Weld Misalignment

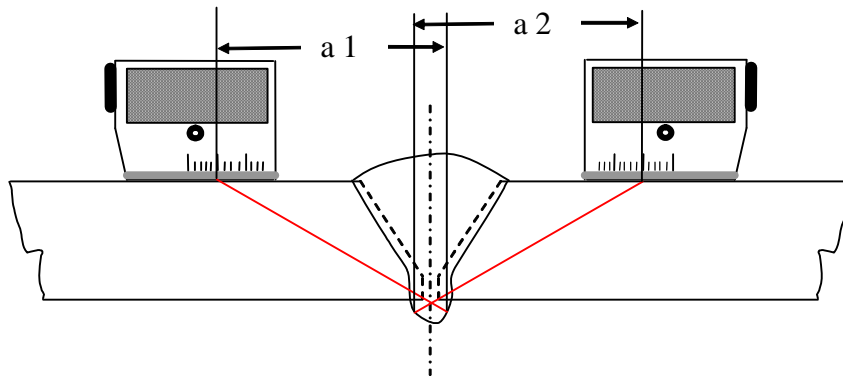

Figure A-5
Excessive root penetration

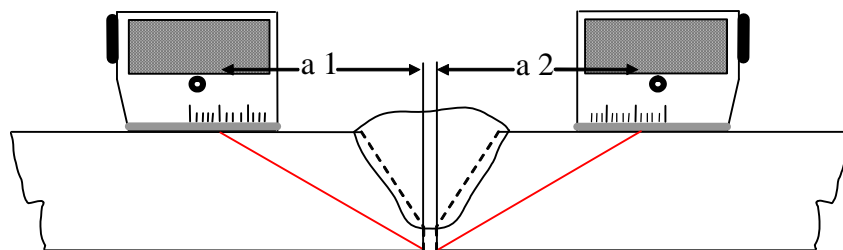

Figure A-6
Lack of root penetration

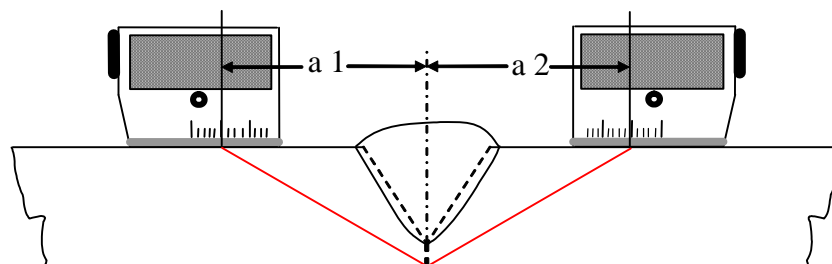

Figure A-7
Root defect